

**Wyoming Department of
Environmental Quality –
Air Quality Division**



WYOMING DEPARTMENT OF
ENVIRONMENTAL
QUALITY

**Quality Assurance Project Plan for Oxides of
Nitrogen/Reactive Oxides of Nitrogen Ambient Air
Monitoring Program**

**December 2024
Revision 3**

Section A. Project Management

1.0 Quality Assurance Project Plan Identification and Approval

Title: Wyoming Department of Environmental Quality, Air Quality Division (WDEQ-AQD) Quality Assurance Project Plan (QAPP) for the Oxides of Nitrogen/Reactive Oxides of Nitrogen Ambient Air Monitoring Program.

This QAPP for the Oxides of Nitrogen/Reactive Oxides of Nitrogen (NO_x/NO_y) Ambient Air Quality Monitoring Program is hereby recommended for approval and commits from the Department to follow the elements described within.

Wyoming Department of Environmental Quality – Air Quality Division



Air Pollution Monitoring Program Supervisor, Leif Paulson

12/18/2024

Date



Quality Assurance Coordinator, Joe Mazza

12/18/2024

Date



Air Pollution Monitoring Program Manager, Mark R. Gagen

12/18/2024

Date

2.0 Table of Contents

Section A. Project Management	1
1.0 Quality Assurance Project Plan Identification and Approval	1
2.0 Table of Contents	2
List of Tables	6
List of Figures	6
Acknowledgments	7
Acronyms	8
3.0 Distribution List	10
4.0 Project/Task Organization	11
4.1 Air Pollution Monitoring Program Manager	12
4.2 Air Pollution Monitoring Program Supervisor	12
4.3 Quality Assurance Coordinator	13
4.4 Project Managers	14
4.5 Monitoring Specialists	14
4.6 Site Operators	14
4.7 Data Manager	15
5.0 Problem Definition/Background	17
5.1 Supporting Documentation	18
6.0 Project Task Description	19
6.1 Nitrogen Dioxide Measurements	19
6.2 Sampling Frequency	19
6.3 Project Schedule	19
6.4 Project Reports	20
7.0 Quality Objectives and Criteria for Measurement of Data	21
7.1 The DQO Process	21
7.2 Data Quality Indicators	23
7.3 Representativeness of the NO _x /NO _y Measurements	24
8.0 Special Training/Certifications	25
9.0 Documents and Records	27
Section B. Data Generation and Acquisition	28
10.0 Network Description	28
11.0 Sampling Method	29

11.1 NO _x /NO _y Analyzers	30
11.2 Support Monitoring Equipment.....	30
11.3 Data Acquisition System	30
11.4 Telecommunications.....	30
11.5 Climate-Controlled Shelter.....	31
11.6 Zero Air System.....	31
11.7 Multi-Gas Dilution Calibrator	31
11.8 Standard Operating Procedures	33
12.0 Sample Handling and Custody.....	34
13.0 Analytical Method.....	35
14.0 Quality Control Requirements	36
14.1 Instrument/Equipment Calibration and Frequency	37
14.2 Visual Inspection of Equipment	41
14.3 Remote Interrogation of Monitoring Station and Inspection of Data.....	41
14.4 Equipment Calibration	41
14.5 Calibration Reference Standard Certification	41
14.6 Zero and Span Checks.....	41
14.7 One-point QC Checks.....	41
15.0 Equipment Maintenance	42
16.0 Instrument Equipment Testing, and Inspection	43
16.1 Acceptance Testing of Instrumentation and Equipment Integration	43
16.2 Site Surveillance and System Check Procedures	43
16.3 Site and Equipment Maintenance	43
17.0 Inspection/Acceptance of Supplies and Consumables	46
17.1 Spare Parts.....	46
17.2 Inspection/Acceptance of Supplies and Consumables.....	46
18.0 Non-Direct Measurements	47
19.0 Data Management	48
19.1 Data Retrieval	48
19.2 Raw Data.....	48
19.3 Data Transfer	48
19.4 DAS Data Review	48
19.5 Data Validation	49
19.6 Data Transmittal	49
19.7 Data Processing	49

19.8 Data Analyses	49
19.9 Data Flagging	49
19.10 Data Submittal to AQS.....	50
Section C. Assessment and Oversight	51
20.0 Assessment and Response Actions	51
20.1 Data Quality Audits.....	52
20.2 Corrective Actions.....	52
20.3 QAPP Revisions	52
21.0 Reports to Management.....	53
Section D. Data Validation and Usability	54
22.0 Data Review, Validation, and Verification Requirements.....	54
22.1 Data Acceptance Limits for NO _x /NO _y	54
23.0 Data Validation and Verification Methods	56
23.1 Level 0 Data Validation	56
23.2 Quality Control Checks for Data Validation.....	56
23.3 Level 1 Data Validation	57
23.4 Minimum Acceptable Data Recovery Percentage.....	59
23.5 Data Report QA Checklist	59
24.0 Reconciliation with User Requirements	60
References	61
APPENDIX A: Standard Operating Procedures	62
Appendix A.1 - Standard Operating Procedures for NO _x and NO _y Analyzers	63
1.0 Scope and Applicability.....	65
2.0 Summary of Method	65
3.0 Health and Safety Warnings	68
4.0 Cautions.....	68
5.0 Personnel Qualifications	69
6.0 Equipment	69
7.0 Quality Control Procedures	70
8.0 Automated Zero/Span/Precision Check	73
9.0 Instrument Performance Calibrations Procedure.....	74
10.0 References.....	77
APPENDIX A FORMS	78
Appendix A.2 Standard Operating Procedure for Performance Evaluations of Gaseous Analyzers.....	83
1.1 Introduction	85

2.0 Summary of Method.....	85
2.1 Definitions	85
3.0 Health and Safety Warnings.....	86
4.0 Cautions	86
4.1 Interferences.....	86
5.0 Personal Qualifications.....	87
6.0 Equipment	87
6.1 Inspection/Acceptance of Supplies and Consumables	87
7.0 Quality Assurance Procedures.....	88
7.1 Instrument Setup and Calibrations prior to Performance Evaluations	88
7.1.1 Equipment Setup in WDEQ-AQD Workshop.....	89
7.1.2 Calibrating MFCs in Calibrator	90
7.1.3 Verification and Reverification of the Level 3 Ozone Field Transfer Standard.....	92
7.2 Field Audits	95
7.2.1 Equipment Setup.....	95
7.2.2 SO ₂ , CO, NO _x , Total Hydrocarbons (THC) Analyzers Audit.....	96
7.2.3 O ₃ Analyzer Audit	98
8.0 References	99
APPENDIX B: Ancillary Information	112
1.0 Instrument Locations.....	114
2.0 Type of Instruments.....	115
3.0 AQS Coding.....	117

List of Tables

Table 1. QAPP Distribution List	10
Table 2. NO ₂ NAAQS and WAAQS Averaging Time, Levels, and Form	17
Table 3. Project Reports.....	20
Table 4. DQO Seven-Step Decision Tree Process.....	22
Table 5. Documents and Reports.....	27
Table 6. NO _x /NO _y Analyzer QC Procedures.....	37
Table 7. Critical Criteria for NO _x /NO _y Analyzers	38
Table 8. Operational Criteria for NO _x /NO _y Analyzers	39
Table 9. Systematic Criteria for NO _x /NO _y Analyzers	40
Table 10. Systematic Criteria for NO _x /NO _y Analyzers Support Equipment.....	42
Table 11. Site Maintenance Activities.....	44
Table 12. Equipment Maintenance Activities	44
Table 13. NO ₂ Audit Levels.....	51
Table 14. Reports to Management.....	53
Table 15. Data Flags	58

List of Figures

Figure 1. WDEQ-AQD Organizational Chart.....	16
Figure 2. WDEQ-AQD NO ₂ Monitoring Site Locations, 1998-2024	18
Figure 3. Illustration of the NO _y Inlet and Molycon Protective Housing	30
Figure 4. Configuration of Monitoring Equipment in the Instrument Rack.....	32

Acknowledgments

Work on documents such as Quality Assurance Quality Plan (QAPP) requires the work and commitment of many dedicated people. This section will acknowledge those that have provided their time and effort to create this document.

Authors and Contributors:

Dennis K. Mikel, T&B Systems, Principle Author

David Bush, T&B Systems, Project Lead

Mr. Mark Gagen, WDEQ-AQD

Mr. Joe Mazza, WDEQ-AQD

Dr. Shelby Watkins, WDEQ-AQD

Additional Reviewers:

Mr. Adam Lenkowski, Trinity

Mr. Christian Kirk, Air Resources Specialists

Mr. Casey Lenhart, Trinity

Ms. Cara Keslar, Trinity

Acronyms

AGL	Above Ground Level
AMTIC	Ambient Monitoring Technology Information Center
APE	Annual Performance Evaluations
APMP	Air Pollution Monitoring Program
APTI	Air Pollution Training Institute
AQD	Air Quality Division
AQS	Air Quality System
ASQ	American Society for Quality
AWMA	Air & Waste Management Association
CFR	Code of Federal Regulations
DAS	Data Acquisition System
DQIs	Data Quality Indicators
DQOs	Data Quality Objectives
E-log	Electronic Logbook
EPA	U.S. Environmental Protection Agency
FRM	Federal Reference Method
GPT	Gas Phase Titration
HVAC	Heating, Ventilation, and Air Conditioning
IMPACT	Inventory, Monitoring, Permitting, And Compliance Tracking system
IMS	Industrial Monitoring Stations
IP	Internet Protocol
IR	Infrared
MFC	Mass Flow Calibrator
MQOs	Measurement Quality Objectives
NAAQS	National Ambient Air Quality Standards
NPAP	National Performance Audit Program
NIST	National Institute of Standards and Technology
NCore	National Core Air Measurement Network
NO	Nitric Oxide
NO ₂	Nitrogen Dioxide
NO _x	Oxides of Nitrogen
NO _y	Total Reactive Oxides of Nitrogen
NO _z	Reactive Oxides of Nitrogen
OAQPS	Office of Air Quality Planning and Standards
PAN	Peroxyacetyl nitrate
PEs	Performance Evaluations
PEP	Performance Evaluation Program
PFA	Perfluoroalkoxy alkane
PMT	Photomultiplier Tube
PQAO	Primary Quality Assurance Organization
PTFE	Polytetrafluoroethylene
QA	Quality Assurance
QAPP	Quality Assurance Project Plan
QC	Quality Control
QMP	Quality Management Plan
SLAMS	State and Local Air Monitoring Stations

SLT	State/Local/Tribal
SOP	Standard Operating Procedure
SPMS	Special Purpose Monitoring Stations
TTP	Through-the-Probe
WAAQS	Wyoming Ambient Air Quality Standards
WDEQ	Wyoming Department of Environmental Quality

3.0 Distribution List

The following individuals listed in Table 1 have been provided a copy of this Quality Assurance Project Plan (QAPP).

Table 1. QAPP Distribution List

Wyoming Department of Environmental Quality, Air Quality Division	
Name	Position
Nancy Vehr	Administrator
Mark Gagen	Air Pollution Monitoring Program Manager
Leif Paulson	Air Pollution Monitoring Program Supervisor
Joe Mazza	Quality Assurance Coordinator
Jacob Berreth	CEMS/SLAMS Coordinator
Lauren Deverse	Exceptional Events Analyst/Project Manager
Ardyss Thai	Data Manager
Jack Kokkinen	Project Manager
Vacant	Project Manager
Vacant	Project Manager
Paul Bailey	Monitoring Specialist
Vacant	Monitoring Specialist
EPA Region VIII	
Name	Position
Aaron Worstell	EPA Region 8, Air Program Tech Unit
Yechan Lim	EPA Region 8, Air Permitting and Monitoring Branch Manager

4.0 Project/Task Organization

Since the early 1970s, the Air Pollution Monitoring Program (APMP) has been committed to monitoring the air quality of Wyoming with the goal of protecting, conserving, and enhancing the quality of Wyoming's environment for the benefit of current and future generations. The APMP provides the WDEQ-AQD with valuable information that allows for the determination of future policy considerations.

The WDEQ-AQD plans, operates, and maintains several different types of ambient monitoring stations, including a National Core air monitoring network (NCore) station, State and Local Air Monitoring Stations (SLAMS), Special Purpose Monitoring Stations (SPMS), Interagency Monitoring of Protected Visual Environment (IMPROVE) monitoring stations, and Industrial Monitoring Stations (IMS).

The SLAMS are sited in populated areas to monitor public health and demonstrate compliance with the National Ambient Air Quality Standards (NAAQS) but may serve other purposes, such as:

- Providing air pollution data to the general public in a timely manner
- Supporting compliance with air quality standards and emissions strategy development
- Supporting air pollution research studies

The SPMS collectively have multiple objectives. These objectives include:

- Providing air pollution data to the general public in a timely manner
- Monitoring public health
- Investigating pollutant concentrations downwind of sources
- Determining background pollutant concentrations

Since 2011, the WDEQ-AQD has operated a fleet of mobile monitoring stations ("mobile stations") to investigate questions or concerns about air quality on a short-term basis (typically one year). Additionally, the WDEQ-AQD administers an NCore station as part of the national network to evaluate long-term trends in air quality. The IMS are independently operated stations that meet the requirements of their permits. Although WDEQ-AQD has oversight authority for the permit-required monitoring networks, the IMS operate as independent Primary Quality Assurance Organizations (PQAOs).

The WDEQ-AQD is committed to quality and the implementation of the procedures and practices found in this QAPP. Quality assurance (QA) is an integrated system of management activities involving planning, implementation, assessment, reporting, and quality improvement to ensure that a process, item, or service is of the type and quality needed and as expected. Quality control (QC) is the overall system of technical activities that measures the attributes and performance of a process, item, or service against defined standards to verify that they meet the stated requirements established by the customer. The QC system includes the operational techniques and activities that are used to fulfill requirements for quality.

Quality control is largely implemented through the QAPP and the standard operating procedures (SOPs). Each instrument in the various monitoring programs have unique requirements, statutory standards, and support equipment that must be in place for the instrumentation to be operated according to the

guidelines, rules, and policies that must be followed. This QAPP incorporates the unique qualities that are specific to nitrogen dioxide and reactive oxides of nitrogen species within the WDEQ-AQD monitoring network.

Implementation of the WDEQ-AQD monitoring program requires an investment by the entire management team up to the Air Pollution Monitoring Program Manager. WDEQ-AQD management recognizes and accepts this responsibility to identify the QA requirements that will meet the needs and expectations of the monitoring program. Any worthwhile monitoring program focuses on preventing quality problems.

Since the WDEQ has an overarching Quality Management Plan (QMP) in place, this and all QAPPs will be mandated by the WDEQ QMP. The QMP describes the quality system in terms of the organizational structure, functional responsibilities of management and staff, lines of authority, and required interfaces for those planning, implementing, assessing, and reporting activities involving environmental data operations.

The following subsections describe the project participants and roles and the responsibilities of each participant. **Figure 1**, which is in the last portion of this section, illustrates that management structure.

4.1 Air Pollution Monitoring Program Manager

The APMP Manager has overall responsibility for managing the WDEQ-AQD according to WDEQ policy and the direct responsibility for assuring data quality rests with line management. Ultimately, the APMP Manager is responsible for establishing QA policy and for resolving QA issues identified through the QA program.

Major QA related responsibilities of the APMP Manager include:

- Participating in the budget and planning processes.
- Assuring that the WDEQ-AQD develops and maintains a current and germane quality system.
- Assuring that the WDEQ-AQD develops and maintains current QAPPs.
- Assuring adherence to the QA documents by staff and, where appropriate, other extramural cooperators establishing policies to ensure that QA requirements are incorporated in all environmental data operations.
- Maintaining an active line of communication with the Monitoring Supervisor, QA Coordinator, and Project Managers conducting management systems reviews.

The WDEQ-AQD APMP Manager delegates the responsibility of QA development and implementation in accordance with WDEQ-AQD policies. Oversight of the WDEQ-AQD's QA program is delegated to the Quality Assurance Coordinator.

4.2 Air Pollution Monitoring Program Supervisor

The WDEQ-AQD Monitoring Supervisor is the delegated manager of the routine monitoring programs, which includes the QA/QC activities that are implemented as part of normal data collection activities. Responsibilities of the APMP Supervisor include:

- Communicating with EPA Project Officers and QA Personnel regarding sampling and QA activities.
- Understanding EPA monitoring and QA regulations and guidance to ensure subordinates understand and follow the regulations and guidance.
- Understanding the WDEQ-AQD's QA policy and ensuring subordinates do as well.
- Understanding and ensuring adherence to the QAPP.
- Reviewing acquisition packages (contracts, grants, cooperative agreements, and interagency agreements) to determine the necessary QA requirements.
- Developing budgets and providing program costs necessary for EPA allocation activities.
- Ensuring that all personnel involved in environmental data collection have access to any training or QA information needed to be knowledgeable in QA requirements, protocols, and technology.
- Certifying to EPA that data are true, correct, and reported to EPA per Title 40 Code of Federal Regulations (CFR) Part 58.15¹.

4.3 Quality Assurance Coordinator

The QA Coordinator is the delegated manager of the WDEQ-AQD's QA Program. The QA Coordinator has direct access to the Administrator, APMP Manager and APMP Supervisor on all matters pertaining to QA. The QA Coordinator's main responsibility is QA oversight and ensuring that all personnel understand the WDEQ-AQD's QA policy and all pertinent EPA QA policies and regulations specific to the APMP. The QA Coordinator provides technical support and reviews and approves QA products. Responsibilities include:

- Developing and interpreting WDEQ-AQD QA policy and revising it as necessary.
- Developing a QA Annual Report for the Administrator.
- Assisting Monitoring Specialists and Project Managers in developing QA documentation and in providing answers to technical questions.
- Ensuring that all personnel involved in environmental data operations have access to any training or QA information needed to be knowledgeable in QA requirements, protocols, and technology.
- Ensuring that environmental data operations are covered by appropriate QA planning documentation (e.g., QAPPs, data quality objectives, etc.).
- Ensuring that reviews, assessments, performance evaluations, and audits are scheduled and completed and, if needed, conducting or participating in QA activities.
- Tracking the QA/QC status of all programs.
- Recommending required management-level corrective actions.
- Serving as the program's QA liaison with EPA Regional QA Managers or QA Officers and the Regional Project Officer.
- Uploads Quality Assurance data to EPA's AQS System.

The QA Coordinator has the authority to carry out these responsibilities and to bring to the attention of the APMP Manager any issues associated with these responsibilities. The QA Coordinator either performs or delegates the responsibility of QA development and implementation.

4.4 Project Managers

Project Managers are responsible for project coordination; oversight of the contractor activities; maintaining the official, approved QAPP; and QAPP distribution. Responsibilities include:

- Ensuring the day-to-day operation and upkeep of all monitors are maintained.
- Overseeing data processing, reporting, and assuring data collection is performed in a timely fashion.
- Understanding EPA monitoring, QA regulations and guidance, and ensuring the Contractors, Monitoring Specialists and Site Operators understand and follow those standards.
- Understanding WDEQ-AQD QA policy and ensuring subordinates understand and follow the policy.
- Understanding and ensuring adherence to the QAPP as it relates to program support activities.
- Participating in the development of data quality requirements with the appropriate QA staff.
- Writing and modifying QAPPs and SOPs.
- Verifying that all required QA activities were performed and quality standards were met as required in the QAPP.

4.5 Monitoring Specialists

The WDEQ-AQD field personnel are responsible for carrying out required tasks and ensuring the data quality results of the tasks by adhering to the guidelines and protocols specified by the QAPP and SOPs for the field activities. Responsibilities include:

- Participating in the implementation of standards, as laid out in the QAPP.
- Keeping up-to-date in training and certification activities.
- Verifying that all required QA activities are performed and quality standards are met (as required by the QAPP).
- Following manufacturer specifications for any equipment used.
- Documenting deviations from established procedures and methods.
- Reporting all problems and corrective actions to the Contractor and Project Manager.
- Preparing and delivering reports to the Project Manager.
- Assessing and reporting on data quality.

4.6 Site Operators

The Site Operators visit the monitoring stations once a month. The Site Operator's role is to do routine maintenance on the monitoring station and instrumentation. For the purpose of this NO_x/NO_y QAPP (and other gaseous parameters), the WDEQ-AQD Monitoring Specialist can perform the duties of the Site Operator. Responsibilities include:

- Change in-line filters on the continuous instruments (monthly).
- Perform unexpected tasks such as running a manual calibration (if necessary after a repair).
- Replace electronic or pneumatic components at the direction of a Contractor or Project Manager.
- Reporting all problems and corrective actions to the Contractor and Project Manager.

- Thoroughly documents all activities performed at a station and reports activities and results to the Contractor and Project Manager.
- Assessing and reporting on data quality.

4.7 Data Manager

The Data Manager reports to the Air Pollution Monitoring Program Manager and is in charge of the WyVisNet website and the AirVision data management system, which runs WyVisNet. Responsibilities include:

- The Data Manager is in charge of uploading data to the EPA's Air Quality System (AQS), which is the National database for all air pollution and meteorological data.
- Ensures data are moved to/from the IMPACT system and shared drives per the WDEQ Records Management Plan.
- Performs data queries within the central database in Cheyenne headquarters.
- Works with the vendors that supply and maintain the WyVisNet software system.
- Performs data analyses as described in Sections 22 and 23 of this QAPP.

Please note that an annual review of the QAPP will be performed and, if no changes are needed, the WDEQ-AQD will document that no changes were necessary. If changes are required, revised pages with the revisions will be inserted/changed, revisions will be tracked, and a new revision number will be assigned to the document.

Figure 1 illustrates the organizational structure for the WDEQ-AQD. For a list of project participants, please see Appendix B.

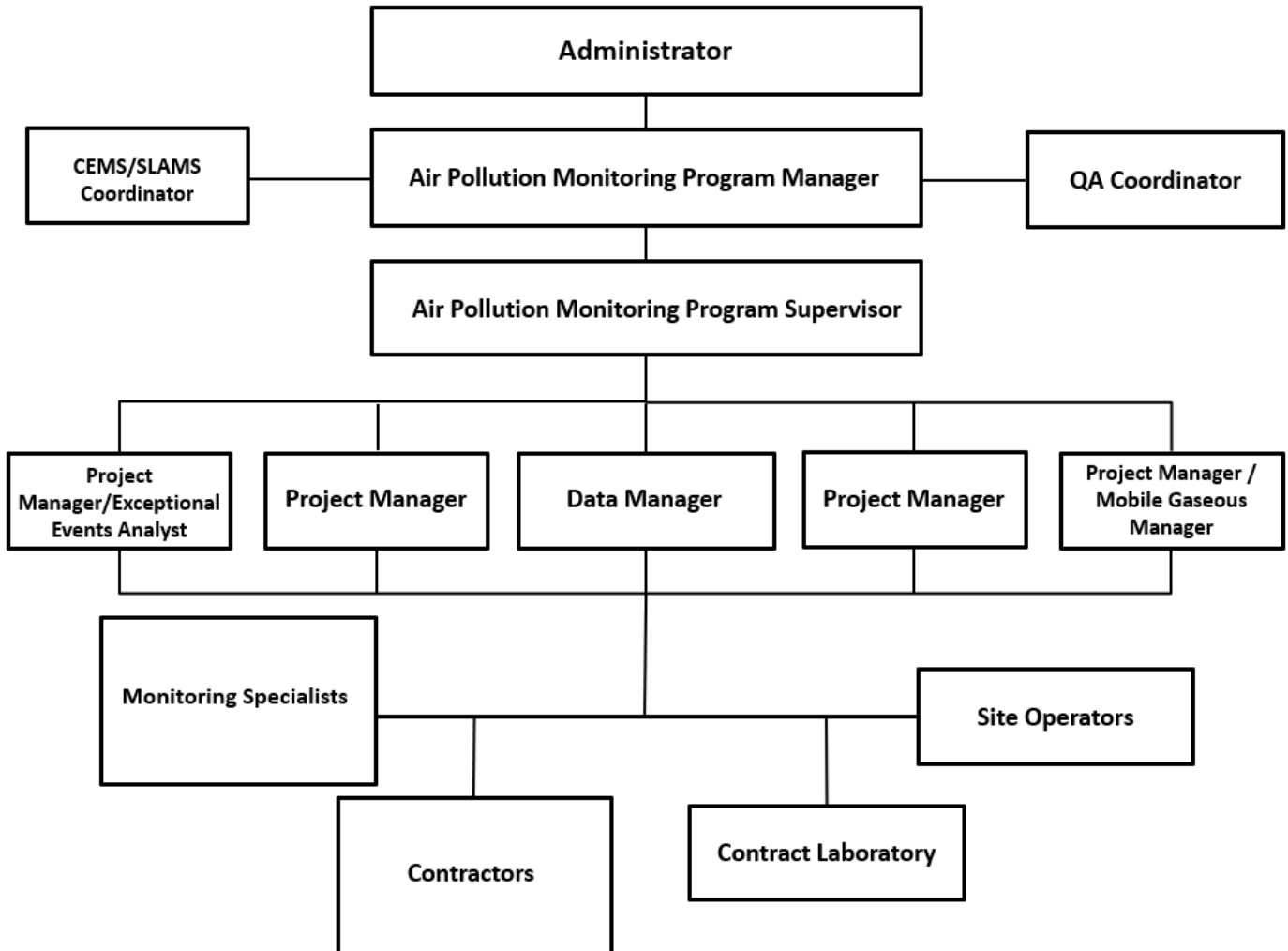

Figure 1. WDEQ-AQD Organizational Chart

5.0 Problem Definition/Background

This QAPP pertains strictly to the collection and analysis of NO_x or NO_y within the WDEQ-AQD monitoring network and details the methodologies to establish precise and accurate NO_x/NO_y measurements at all stations within the WDEQ-AQD monitoring network, regardless of the type of monitoring that is performed.

The objective of the monitoring network is to provide the necessary information for developing a representative air quality data set capable of delineating differences among geographical and climatological regions. The monitored data are used to characterize and monitor trends in air quality and air quality standards' compliance and may be used for national health assessments, model evaluations, and comparison with other ambient air monitoring data. The procedures outlined in this QAPP have been developed to meet the goals and objectives of the monitoring project. Revisions to the QAPP are made, as necessary, to reflect changes to the regulations or goals of the monitoring project. As a minimum, the QAPP is reviewed annually and revisions are made as necessary on an annual basis.

Every year the WDEQ-AQD publishes an Annual Network Plan¹, which discusses the monitoring operations for each station in Wyoming, including all the monitoring stations that will monitor for NO_x/NO_y parameters. Every five (5) years, a Network Assessment is published by the WDEQ-AQD, which discusses in detail the status of the monitoring stations and the need for additional monitoring. The stations at which the WDEQ-AQD currently operates NO_x/NO_y analyzers are listed in Appendix B, Instrument Locations.

The NAAQS one-hour primary standard is met when a one-hour average of Nitrogen Dioxide (NO₂) exceeds 100 ppb or exceeds an annual mean of 53 ppb (see **Table 2**). At the writing of this QAPP, no stations within the State of Wyoming were considered in Non-Attainment. Please note, that the Cheyenne NCore station and Boulder station each have one NO_y analyzer in addition to NO_x analyzers. All other stations have NO_x analyzers only. The distinctions between NO_y and NO_x analyzers will be discussed in Section 15.

Table 2. NO₂ NAAQS and WAAQS Averaging Time, Levels, and Form

Pollutant	Primary/Secondary	Averaging Time	Level	Form
NO ₂	Primary	1-hour	100 ppb	98 th percentile of 1-hour daily maximum concentrations averaged over 3 years
	Primary and Secondary	Annual	53 ppb	Annual Mean

Below is **Figure 2**, which illustrates the WDEQ-AQD Monitoring Stations, both past and present. As it can be seen from this map, the WDEQ-AQD monitoring network covers the entire State.

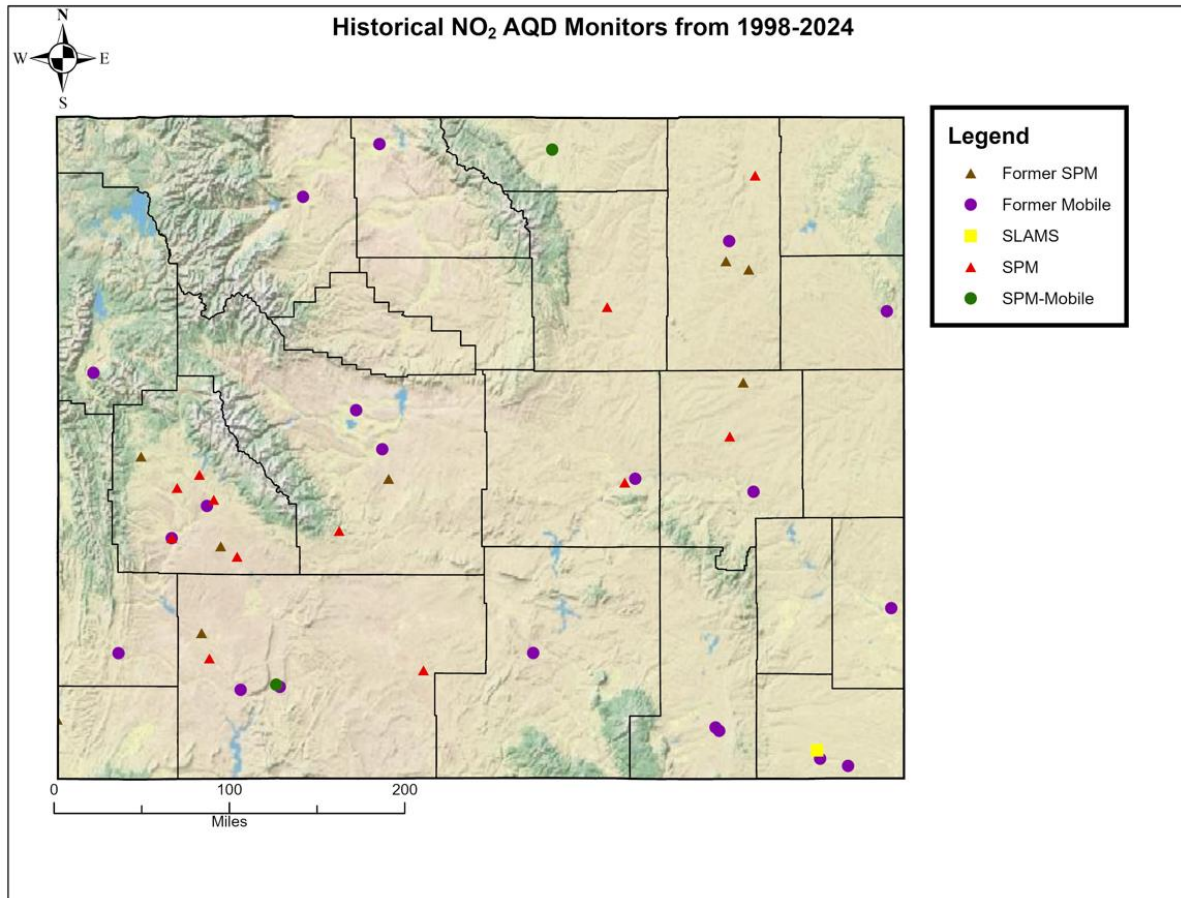

Figure 2. WDEQ-AQD NO₂ Monitoring Site Locations, 1998-2024

5.1 Supporting Documentation

The information collected for this monitoring program will meet the requirements as found in the following documents:

- 40 CFR Part 58, Appendices A-E²
- 40 CFR Part 50, Appendix F³
- Quality Assurance Handbook for Air Pollution Measurement Systems, Volume II: Ambient Air Quality Monitoring Program, EPA-454/B-17-001, January 2017⁴
- Technical Assistance Document (TAD) for Precursor Gas Measurements in the NCore Multi-Pollutant Monitoring Network, Version 4, EPA-454/R-05-003, September 2005⁵
- Quality Assurance Handbook for Air Pollution Measurement Systems, Volume I: Principles, EPA-600/9-76-005, December 1984⁶
- Technical Assistance Document for Sampling and Analysis of Ozone Precursors for the Photochemical Assessment Monitoring Stations Program, EPA Document EPA-454/B-19-004, April 2019⁷

The guidance presented in the above-listed documents will be followed for this monitoring program and is intended to ensure that the data collected and technical information are documented and of appropriate quality and usability.

6.0 Project Task Description

6.1 Nitrogen Dioxide Measurements

Oxides of nitrogen are released from emission sources primarily as nitric oxide (NO) and to a lesser extent as nitrogen dioxide (NO₂). The two species are collectively termed NO_x (NO_x = NO + NO₂). Through atmospheric processes, NO_x is converted to many other inorganic and organic nitrogen oxides, such as:

- nitrous acid (HONO);
- nitric acid (HNO₃);
- peroxyacetyl nitrate (H₃CC(O)OONO₂, or PAN).

Collectively, these three species are known as NO_z. Therefore, the total of all reactive nitrogen species is NO_y, which the EPA recognizes as the sum of NO_x and NO_z (i.e., NO_y = NO_x + NO_z).

In addition to NO₂ being a criteria pollutant in the NAAQS and WAAQS, it also plays a critical role in the photochemical production of ozone. Accurate measurement of NO₂ concentrations in ambient air is necessary to support air quality modeling efforts aimed at evaluating and tracking the progress of control strategies for attaining the ozone NAAQS.

6.2 Sampling Frequency

Data from the NO_x/NO_y analyzers are sampled every second by the Data Acquisition System (DAS). The DAS then stores the data in 1-minute and hourly average increments (at a minimum). This data is then transmitted and reviewed by WDEQ-AQD and the Contractors on a defined interval at their central location.

6.3 Project Schedule

Personnel working on this project are fully qualified, trained, and capable to perform their assigned duties. Work schedules include: daily data review, quarterly and semi-annual air quality equipment calibrations, quarterly data summaries within 60 days of quarter completion, annual reports within 90 days of year completion, and maintenance and corrective action.

6.4 Project Reports

Table 3 presents the reports that will be produced as part of this project.

Table 3. Project Reports

Reports	Frequency	Content	Responsible Position
Quarterly Data Reports	Quarterly	Summarizes data following EPA guidelines, including accuracy and precision	Contractor with review by Project Manager
Annual Data Report	Annually	Summarizes data following EPA guidelines	Contractor with review by Project Manager
Performance Audit Reports	Semi-annually	Summarizes audit results following EPA guidelines	WDEQ-AQD QA Coordinator or Contractor with review by Project Manager
Corrective Action Reports	As Needed	Summarizes corrective actions taken to return the monitoring station to compliant status	Contractor with review by Project Manager
Response to Corrective Action Reports	As Needed	Reports the results of the corrective actions taken	Contractor with review by Project Manager

7.0 Quality Objectives and Criteria for Measurement of Data

This section discusses the Data Quality Objectives (DQOs), Measurement Quality Objectives (MQOs) and Data Quality Indicators (DQIs) that are mandatory for all monitoring programs.

Generally, the DQOs for any program are created by the stakeholders. The DQO process is a seven-step decision tree that allows the stakeholders of the WDEQ-AQD to define parameters for the program. The DQO process has been in existence for many years, first by the EPA and then utilized by the State, Local and Tribal governments that are required to collect data on behalf of the EPA. Please note that it is outside of the scope of this document to discuss whether or not the State of Wyoming, or parts of the state, are in attainment. Please refer to the WDEQ-AQD Annual Network Plan 2024¹ for the discussion of attainment for Nitrogen Dioxide. In addition, please note that of all of the NO_x/NO_y species, only NO₂ has a NAAQS/WAAQS attainment status.

As mentioned before, the DQO is a seven-step process that takes the form of a discussion of the important aspects of the program. It is encouraged and useful that the DQO process is performed from time to time to ensure that the objectives are clear and concise.

7.1 The DQO Process

On August 12, 2020, the WDEQ-ADQ and its Contractor met to discuss the DQOs for the programs and define the objectives. **Table 4** below outlines the discussion and the outputs of the DQO process in each step.

In order for the DQOs to be fulfilled, MQOs are designed to evaluate and control various phases (sampling, preparation, and analysis) of the measurement process to ensure that total measurement uncertainty is within the range prescribed by the DQOs. MQOs can be defined in terms of the following DQIs: precision, bias, representativeness, detectability, completeness, and comparability.

Table 4. DQO Seven-Step Decision Tree Process

DQO Step	Output to Discussion by Decision Makers
Step 1. State the Problem	The State of Wyoming, being within the bounds of the United States, must adhere to the Clean Air Act Amendments. The Code of Federal Regulations 40 part 50 set the NAAQS and the State of Wyoming measures for the NAAQS pollutants. In addition, the State of Wyoming promulgated its own Ambient Air Quality Standards (WAAQS), which are identical to the NAAQS. The State of Wyoming must comply with these standards and thus measure in various locations to meet the requirements. In addition, EPA requires that each state must operate a National Core (NCore) monitoring station and one of the requirements for an NCore monitoring station is to operate an NO _y analyzer.
Step 2. Identify the Goal of the Study	Not only does the State of Wyoming have to measure for NO ₂ NAAQS pollutants, but it must also adhere to the level of the standard (attainment vs. non-attainment as promulgated in 40 CFR Part 50). An additional goal for this network is to understand the reactivity of the atmosphere in urban areas. This is the reason for the NO _y monitoring at the NCore monitoring station in the metropolitan area of Cheyenne.
Step 3. Identify Information Input	The input information is the hourly average data that is collected at the locations where NO _x /NO _y are monitored.
Step 4. Define the Boundaries of the Study	The boundary of the study is the entire State of Wyoming. Within the State, there are two Primary Quality Assurance Organizations (PQAOs). The two divisions of PQAOs are the WDEQ-AQD and the independent industrial monitoring PQAOs.
Step 5. Develop the Analytical Approach	The WDEQ-AQD will collect NO _x /NO _y data at the monitoring locations stated in Appendix B. At the end of the year, the WDEQ-AQD will review, analyze and certify that the data collected within the WDEQ-AQD network are valid within the parameters as laid out in this QAPP.
Step 6. Specify Performance Criteria	The performance criteria are described in this QAPP under the MQOs and thus the DQIs. If the data collected adhere to these performance criteria, then the data can be used to ascertain if the State of Wyoming is within non-attainment or attainment status. The results of the decisions on attainment are discussed in detail within the WDEQ-AQD Annual Network Plan ¹ .
Step 7. Develop the Plan for Obtaining Data	Having developed these DQOs, the WDEQ-AQD has developed this NO _x /NO _y QAPP and SOP to ensure that the QA and QC procedures are documented and followed by WDEQ-AQD staff and their Contractors.

7.2 Data Quality Indicators

The data quality indicators (DQIs) are a set of indicators that can be easily measured. For instance, precision and bias can be calculated using statistical methods on the data. The other DQIs are either inherent in the NO_x/NO_y analyzers, i.e. detection limits, or indicate how the samples are handled and analyzed.

Here is a discussion of each DQI:

- **Precision** - a measure of agreement among repeated measurements of the same property under identical, or substantially similar, conditions. This is the random component of error. Precision is estimated by various statistical techniques typically using some derivation of the standard deviation. For NO_x/NO_y, precision is determined based on the three-day zero, span, and precision checks.
- **Bias** - the systematic or persistent distortion of a measurement process that causes error in one direction. Bias will be determined by estimating the positive and negative deviation from the true value. Bias is determined by using the paired data from the 1-in-3 day QC checks.
- **Detection Limit** - the lowest concentration or amount of the target analytic that can be determined to be different from zero by a single measurement at a stated level of probability. For the high-sensitivity instruments, this is an important DQI. The EPA specifies how and how often this test is performed, which is recommended annually. The specific procedures are detailed in the SOP for NO_x/NO_y analyzers, which is a companion document to this QAPP.
- **Completeness** - the amount of valid data obtained from a measurement system compared to the amount that was expected to be obtained under normal conditions. Data completeness requirements are discussed in NAAQS (40 CFR Part 50)³.
- **Comparability** - generally falls under the auspice of equipment specifications and monitoring methods. For the example of NO_x, only Federal Reference Method (FRM) analyzers are used for data collection. The methodology used is to draw the air samples into the analyzer using federally approved glassware and Teflon tubing.
- **Representativeness** - this DQI deals with whether or not the location of the NO_x/NO_y analyzer represents the type of monitoring that is necessary, i.e., is the station sited appropriately for the objective.
- **Accuracy** - a measure of the overall agreement of a measurement to a known value, including a combination of random error (precision) and systematic error (bias) components of sampling. This is performed using annual performance evaluations (APEs). In addition, the EPA or its designee will also perform through-the-probe (TTP) audits (as part of the National Performance Audit Program (NPAP)). These QA procedures are discussed in more detail in Section 20 of this QAPP.

For NO_x/NO_y measurements, the goal for acceptable measurement uncertainty (precision) is an upper 90 percent confidence limit for the coefficient variation (CV) of <10.0 percent (%). The bias for NO_x/NO_y is expressed as an upper 95% confidence limit for the absolute bias of <10.0%.

7.3 Representativeness of the NO_x/NO_y Measurements

Site selection and probe placement follow guidelines in the following US EPA documents to assure that measurements are representative of meteorological and air quality monitoring conditions near the monitoring station:

- Quality Assurance Handbook for Air Pollution Measurement Systems, Volume I: A Field Guide to Environmental Quality Assurance 1994⁶
- Quality Assurance Handbook for Air Pollution Measurement Systems, Volume II: Ambient Air Quality Monitoring Program, EPA-454/B-17-001, January 2017⁴
- 40 CFR 58, Appendices A, C, and E²
- Technical Assistance Document for Precursor Gas Measurements in the NCore Multi-Pollutant Monitoring Network, Version 4, EPA-454/R-05-003 September 2005⁵

The monitoring sites that were selected to house the NO_x/NO_y analyzers were selected to be as representative as possible of the general region of interest. The placement of a shelter considers local interferences, distance to structures, trees, and roadways, and the height of the probe above ground. The network was set up in accordance with EPA-defined ambient air quality siting criteria.

8.0 Special Training/Certifications

Personnel assigned to the ambient air monitoring programs will meet the educational, work experience, responsibility, and training requirements for their positions. Records on personnel qualifications and training will be maintained in personnel files and will be accessible for review during audit activities. All WDEQ-AQD staff will follow the APMP's training plan and provide proper documentation and tracking.

Adequate education and training are integral to any monitoring program that strives for reliable and comparable data. It is recommended that WDEQ-AQD maintains some requirements for personnel qualifications (combination of education and experience). Training is aimed at increasing the effectiveness of employees and their organization.

As part of a quality assurance program, the procedures should include information on:

- Personnel qualifications (general and position-specific)
- Training requirements (based on position)
- Frequency of training

Appropriate training should be available to employees supporting the Ambient Air Quality Monitoring Program and commensurate with their duties. Such training may consist of classroom lectures, workshops, web-based courses, teleconferences, vendor-provided and on-the-job training. Training should also include appropriate reading materials, such as the CFR, EPA guidance documents, and the WDEQ-AQD's QAPPs and SOPs, to name a few.

EPA encourages monitoring organizations to maintain documentation that details the training provided to all monitoring staff, along with documentation that illustrates the successful completion of the training requirements. Along with suggested training, some EPA programs require mandatory training and/or certifications. These programs include, but are not limited to, the National Performance Audit Program (NPAP) and the Performance Evaluation Program (PEP). All personnel performing audits in these projects or programs are required to possess mandatory training or a current certification issued by the EPA Office responsible for the monitoring program. EPA encourages regional planning organizations and monitoring organizations to develop training programs that require some level of certification. Over the years, several courses have been developed for personnel involved with ambient air monitoring and quality assurance aspects.

Formal QA/QC training is offered through the following organizations:

- AirKnowledge <https://airknowledge.gov/>
- Air & Waste Management Association (AWMA) <https://www.awma.org/>
- American Society for Quality (ASQ) <https://asq.org/>
- EPA Quality Program <https://www.epa.gov/quality>
- EPA Regional Offices <https://www.epa.gov/aboutepa/regional-and-geographic-offices>
- EPA Ambient Monitoring Technology Information Center (AMTIC) Technology Transfer Network <https://www.epa.gov/amtic>

WDEQ-AQD should consider adding manufacturer-provided training to the equipment purchase cost. Personnel having experience in the subject matter described in the courses would select courses according to their appropriate experience level. Courses not included in the core sequence would be selected according to individual responsibilities, preferences, and available resources.

9.0 Documents and Records

The WDEQ-AQD is committed to fully documenting all activities related to data collection, analysis, validation, and reporting. **Table 5** contains a list of the records maintained by the WDEQ-AQD monitoring program. These records can be electronic, bound in notebooks, and/or forms that are used for specific applications. Electronic records will be stored on main office storage drives and archived by the Contractors and ultimately, the WDEQ-AQD office servers. All project files are backed up daily. In addition, weekly network backup occurs. The weekly backup network files are stored on external hard drives which are stored off-site. The WDEQ-AQD has several of these backup hard drives and copies of the field logbook are archived in the WDEQ-AQD Cheyenne office for 5 years.

Table 5. Documents and Reports

Documentation Type	Frequency	Report Submission	Archive	Retention Period
Monitoring Data	Daily Downloads	Contractors	WDEQ-AQD and Contractor's Server (with backup)	5 years
QAPP and SOPs	Annually or more frequently, as needed	QA Coordinator	WDEQ-AQD	5 years
Copies of Field Logbooks	After each site visit	Site Operators and Contractors	WDEQ-AQD and Contractors	5 years
Quarterly Reports	Quarterly	Contractors	WDEQ-AQD and Contractors	5 years
Annual Data Report	Annually	Contractors	WDEQ-AQD and Contractors	5 years
Performance Audit Summaries	Semi-Annually	QA Coordinator or Contractor	WDEQ-AQD	5 years

All monitoring data, reports and program documentation will be retained by the WDEQ-AQD for a minimum of five (5) years. The WDEQ-AQD will review and approve changes to the QAPP given updates or changes to the Records Management Plan.

Section B. Data Generation and Acquisition

10.0 Network Description

This section describes the project design and implementation of the NO_x/NO_y monitoring network. For the list of current locations and a description of the NO_x/NO_y monitoring network, please see Section 1.0 of Appendix B, Instrument Locations.

11.0 Sampling Method

NO_x/NO_y photometry is a spectrophotometric method that has been used since the early 1980s and is the preferred method for measuring oxides of nitrogen species, whether reactive or not.

NO_x and NO_y analyzers work primarily in the same manner, nitric oxide (NO) is shunted into a chamber with ozone and the following reaction occurs:

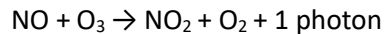

Next to the reaction chamber is a highly sensitive photomultiplier tube (PMT). The PMT is able to convert the photon to an electron. The circuitry within the analyzer counts the number of electrons captured and converts that to a current that is directly related to the concentration of NO in the chamber. The main difference between the NO_x and NO_y analyzer is that the NO_y analyzer has an external molybdenum converter (Molycon) that converts all NO_z species to NO. The NO_x analyzer has an internal Molycon and converts NO_x species to NO. By integrating a solenoid valve switching system, the analyzer measures NO in one cycle and NO_x/NO_y in the other. The analyzer records the data internally and communicates that information to the DAS.

NO is a stable gas that can be stored in compressed aluminum cylinders. Because of this, cylinders can be filled with known concentrations of NO and shipped to any location. The NO concentrations, if high enough, can be stable in the cylinders for many years. Several gas vendors lease or sell cylinders that are traceable to the National Institute of Standards and Technology (NIST) traceable standards for NO. In this manner, cylinders can be leased of known concentrations and taken to the ambient air monitoring locations throughout the State of Wyoming. If properly stored and utilized, cylinders can be used to calibrate, verify or audit the instruments in the field. Please note that gas cylinders must be stored safely and requires strapping or chaining the cylinder in a vertical position to a wall or secured fastened bench.

The NO_x/NO_y analyzers operated by the WDEQ-AQD are placed in monitoring shelters across the state. The samples are drawn into the instrument as described in the Quality Assurance Handbook for Air Pollution Measurement Systems: Volume II⁴ and Technical Assistance Document for Precursor Gas Measurements in the NCore Multi-Pollutant Monitoring Network⁵. NO_x is measured by sampling ambient air from either a borosilicate glass manifold or sample lines that are made of PTFE or PFA Teflon. For NO_x measurements, the sampling inlet is on the roof of the shelter approximately 4 meters above ground level (AGL). The Teflon sampling line or glass manifold is protected by a pipe with a Teflon-coated cover protecting the inlet probe. A Teflon particulate filter also protects the sampling line.

For NO_x instruments, the Teflon Inlet line is connected to a borosilicate glass manifold. The NO_x analyzer uses a Teflon line to connect to a port on the manifold. A pump is connected to the end of the manifold to keep the residence time as low as possible. The residence time of the analyzers will be maintained at less than 20 second residence time requirement. NO_x/NO_y probe siting information and site configuration for the monitoring is in accordance with 40 CFR Part 58 Appendix E².

Because the NO_z species that exist in the atmosphere are so reactive, the species must be converted to NO before they enter the monitoring station. As mentioned earlier, the Molycon is mounted externally on top of a 10-meter tower.



Figure 3. Illustration of the NO_y Inlet and Molycon Protective Housing

11.1 NO_x/NO_y Analyzers

For a list of the current analyzers utilized throughout the WDEQ-AQD monitoring network, please see Appendix B, Types of Instruments.

11.2 Support Monitoring Equipment

The operating range of the analyzers easily brackets the range of environmental conditions expected at the site. The SOP for NO_x/NO_y analyzers details the calibration and operation of the equipment. The supporting equipment used at the monitoring stations are discussed in the following sections.

11.3 Data Acquisition System

Instantaneous data from the NO_x/NO_y analyzers are transferred once per second to the DAS usually by a serial cable. The DAS is a self-contained box with the ability to measure and control electronics, and communicate with on-site computers or remote systems. Data is generally stored in a table format. Please note that the DAS stores 1-minute and hourly data (at a minimum). The one-second data is not stored. In addition, the DAS communicates with the multi-gas dilution calibrator and initiates automated zero, precision and span checks. The DAS records the response to the checks and then can compare that response to the expected value.

11.4 Telecommunications

Telecommunication services are used for high-speed remote communication to all on-site equipment, including the DAS. Additionally, each analyzer on-site is configured with a unique internet protocol (IP)

address for remote maintenance and control purposes. The gateway has all of the firewall protection and routing protocols necessary for protection, isolation, and security.

11.5 Climate-Controlled Shelter

The shelter temperature is maintained by a heating, ventilating, air conditioning (HVAC) system. The temperature is controlled by a thermostat located within the shelter. The temperature is maintained at 20-30 °C at all times. The shelter houses the analyzers, calibration equipment, sample intake manifold, DAS and cylinders.

11.6 Zero Air System

In order to determine the baseline of the analyzer and its detection limit, a zero air system is used. The zero air system is a fully self-contained source of high purity zero air for dilution calibrators. It is ideal for use with highly sensitive analyzers in ambient background and trace level applications. The zero air system includes a dew point sensor, an oil and diaphragm-free pump, and scrubbers to remove all pollutants measured.

The regenerative, heatless dryer removes water and produces output with a dew point less than -40°C (up to a flow rate of 30 standard liters per minute (SLPM)). The system's pressure, temperature, and dew point values are all continuously monitored, which allows a microcontroller to adjust the pump cycling frequency, valve timing, and heater power for optimal performance. The WDEQ-AQD Contractors will perform an annual zero air test. This is performed by substituting the zero air generator with a compressed gas zero air cylinder from a verified gas vendor. The gas cylinder is hooked up to the Mass Flow Controller unit and all analyzers are allowed to sample the zero air from the cylinder. The zero response of the NO_x/NO_y analyzer is then compared to the zero air response from the zero air generator.

11.7 Multi-Gas Dilution Calibrator

The multi-gas dilution calibrator is an integrated gas flow controlling device that contains mass flow controllers (MFCs) that can flow and mix pressurized gases and zero air in very precise and accurate amounts to be shunted to the analyzers. A high pressure cylinder with a known concentration of NO gas flows from the cylinder and is shunted through a solenoid valve. This gas is then mixed with "zero air", i.e., air that has less than 1.0 part per billion (ppb) of NO or NO₂ in a mixing chamber. For the trace level analyzers, the zero air must contain less than 50 parts per trillion (ppt). Once the zero air and NO are mixed, it is allowed to enter the station manifold. The analyzer draws in the gas and measures the concentration. Since the gas in the cylinder is NIST traceable and of known concentration and the air flow of the zero air generator is known, the instrument can be verified and or calibrated. Thus the traceability of the NIST concentration in the cylinder is transferred to the instrument.

In addition to verifying or calibrating the instruments with NO gas, the multi-gas dilution calibrator has the ability to mix a diluted NO gas mixture with ozone. This process is known as a gas phase titration (GPT). When NO is mixed in a chamber with ozone, it immediately converts the NO to NO₂. The GPT provides a very important function for the NO_x/NO_y analyzer; testing of the Molycon's ability to convert NO₂ to NO. The procedure for performing the GPT is described in detail in the SOP for NO_x/NO_y

analyzers. As noted previously, the NO_y analyzer has a Molycon exterior to the analyzer and is mounted on top of a 10-meter tower. The NO/NO₂ gas from the dilution calibrator must be pumped through a Teflon line to the Molycon so that it can sample the mixture and convert the NO₂ to NO and be measured by the NO_y analyzer.

Figure 4 illustrates the configuration of the monitoring equipment and the placement of this equipment at a typical monitoring site.



Figure 4. Configuration of Monitoring Equipment in the Instrument Rack

11.8 Standard Operating Procedures

An SOP has been developed to provide instructions to the Site Operators regarding the routine operation of the NO_x/NO_y analyzers. The SOP for NO_x/NO_y analyzers covers the manual zero, span, precision checks, and calibrations. Equipment inspection, acceptance testing, visual inspections and preventive maintenance are detailed in the operations manual that accompanied the analyzer upon purchase. The SOP for NO_x/NO_y analyzers is an independent document that is a companion to this QAPP. The identification, cause, and corrective action for conditions adverse to quality will be documented on the corrective action report form (see the SOP). Follow-up action will be taken by the Contractor and Project Manager to verify the corrective action was taken.

12.0 Sample Handling and Custody

For the NO_x analyzers, the air quality samples are collected through Borosilicate glass or Teflon tubing which extends to the outside of the shelter. Both Borosilicate glass and/or Teflon are considered acceptable by the EPA for use as intake sampling material for all reactive gaseous pollutants. The residence time is defined as the amount of time that it takes for a sample of air to travel from the opening of the cane to the inlet of the analyzer and is required to be 20 seconds or less (recommended 10 seconds or less).

For the NO_y analyzers, the Molycon is housed outside of the shelter on top of a 10 meter tower. The sample is drawn into the housing into a solenoid valve that is controlled by the instrument. In one configuration, the solenoid directs the airflow through the Molycon and all species of NO_y (excluding NO, which remains unreacted) are converted to NO. The air then flows to the reaction chamber of the analyzer and the NO_y is measured. The solenoid then switches and the air is directed around the Molycon and the NO in the atmosphere is measured. All lines that are associated with the sample are either Teflon or Stainless Steel before it enters the reaction chamber.

13.0 Analytical Method

The NO_x/NO_y analyzer is a self-contained, microprocessor-controlled instrument that is based on the reaction of NO (or NO_y species converted into NO) with ozone in a reaction chamber. The reaction of NO and ozone give off one photon per molecular reaction. This photon is converted into an electrical current by a PMT. The NO_x/NO_y analyzers do not require any laboratory analyses. Section 6 of this QAPP gives a detailed description of the measurement principle of NO_x/NO_y analyzers.

The WDEQ-AQD only utilizes FRMs, which have been rigorously challenged by the EPA in the Research Triangle Park, North Carolina laboratory to operate within the parameters set by the EPA. The FRM designation for the WDEQ-AQD NO_x analyzers are: (Teledyne-API T200U) RFNA-1194-099 and (Thermo 42i) RFNA-1289-074. The NO_y analyzer (Teledyne-API T200U/NO_y) does not have an EPA designation since it does not measure NO₂.

14.0 Quality Control Requirements

This section describes the routine quality control procedures used for the NO_x/NO_y monitoring program. All procedures have been specifically designed to provide the appropriate quality control and ensure that valid data recovery meets or exceeds the WDEQ-AQD data recovery requirements of 90 percent per quarter for NO_x/NO_y monitoring.

The WDEQ-AQD monitoring program will follow the quality control guidelines as stated in the following documents:

- 40 CFR 58, Appendices A – E²
- Quality Assurance Handbook for Air Pollution Measurement Systems Volume II: Ambient Air Quality Monitoring Program, EPA-454/B-17-001, January 2017⁴
- Technical Assistance Document for Precursor Gas Measurements in the NCore Multi-Pollutant Monitoring Network, Version 4, EPA-454/R-05-003 September 2005⁵
- Technical Assistance Document for Sampling and Analysis of Ozone Precursors for the Photochemical Assessment Monitoring Stations Program, EPA Document EPA-454/B-19-004, April 2019⁷

14.1 Instrument/Equipment Calibration and Frequency

See Appendix A: Standard Operating Procedures for additional information

Table 6. NO_x/NO_y Analyzer QC Procedures

Procedure	Frequency	Requirement
Visual Inspection of Equipment	Each site visit; typically once a month	As needed
Remote interrogation of the monitoring station and inspection of data	Daily	QC checks for data screening
Calibration	Quarterly	Meets MQO
Cylinder Certification	Depending on the mixture of gases in the cylinder, once every three years (specified the on Certificate of Analysis).	Ship the cylinder to the gas vendor for recertification to NIST Traceable Standards.
Zero/span checks	Once every 3 days	Meets MQO
Precision checks	Once every 3 days	Meets MQO
Equipment Maintenance	As needed or as the operating manual recommends	See SOP and instrument manuals
In-line filter change	Each site visit; once a quarter or as needed	As needed
Data validation	Daily and monthly	Electronic data screening time/parameter plot visual check
	Quarterly	Data processing calculation check. Missing data: confirmed off-line periods, confirmed data validation checklist.

Table 7, Table 8, and **Table 9** on the following pages, contains some specific criteria for data validation and audits for the NO_x/NO_y analyzers. Some of the data validation criteria will be discussed in later chapters on data validation and review.

Table 7. Critical Criteria for NO_x/NO_y Analyzers

Requirement	Frequency	Acceptance Criteria	Reference	Action
One-Point QC check (NO ₂ Only)	3 days	<±15.1 % (percent difference) or <±1.5 ppb difference whichever is greater	40 CFR Part 58 App. A, Section 3.1.1 ²	Points outside of acceptance criteria are repeated and data is invalidated to the last acceptable multipoint calibration or ZPS check, or to a point in time where the analyzer failure is identified.
		≤±10.1%	WDEQ-AQD action limit criteria	Contractor will evaluate the cause/issue, email the Project Manager and discuss a course of action
Zero/span check	3 days	Zero drift: ≤±3.1ppb (24 hr.) ≤± 5.1 ppb (>24hr - 14 day) Span drift: ≤±10.1%	EPA QA Handbook Vol. II, Section 12.3 ⁴	Invalidate data to the last acceptable zero/span check or to a point in time when the analyzer failure is identified. Adjust analyzer and perform multipoint calibration.
		Zero drift: ≤± 1.5 ppb (24 hr.) Span drift: <± 7%	WDEQ-AQD action limit criteria	Contractor will evaluate the cause/issue, email the Project Manager and discuss a course of action
Converter Efficiency	Less than 14 days	≥96%	EPA QA Handbook Vol. II ⁴	Replace or service converter.

Table 8. Operational Criteria for NO_x/NO_y Analyzers

Requirement	Frequency	Acceptance Criteria	Reference	Action
Verification/ Calibration and Multipoint Calibration	Quarterly or after failed QC check or maintenance	Instrument residence time ≤ 2 minutes. All points within ≤±2.1% or ≤±1.5 ppb difference of best-fit straight line whichever is greater and slope 1±0.05	40 CFR Part 50, App F ³	The slope criteria is only a recommendation, but it is required to be presented in quarterly/annual reports.
Annual Performance Evaluation (Audit)	<u>40 CFR Part 58 requirement</u> : Every site 1/year within period of monitor operation, 25% of sites quarterly <u>WDEQ-AQD requirement</u> : All sites semi-annually, Boulder and Cheyenne NCore locations quarterly	Audit levels 1&2 <±1.5 ppb difference or <±15.1%; Audit levels 3-10 ≤±15.1%	40 CFR Part 58, Appendix A Section 3.1.2 ²	Zero point and at least three gas points. Points outside acceptance criteria are repeated. If still outside, invalidate data to the last acceptable calibration.
Detection limit	Annually	≤ 10 ppb or instrument manual specification	40 CFR Part 53.23(C) ⁸	Rerun detection limit test.
Noise	Annually	≤ 5 ppb or instrument manual specification	40 CFR Part 53.23 (b) ⁸ ; 40 CFR Part 53.23 Table B-1	Refer to the instrument manual.
Shelter Temperature	Daily	20-30°C	EPA QA Handbook Vol. II ⁹ , Sec 7.2.2	Flag data for which temperature range are outside of acceptance criteria.
Shelter Temperature Control	Daily	< 2.1°C SD over 24 hours	EPA QA Handbook Vol. II ⁹ , Sec 7.2.2	Flag data for which temperature range are outside of acceptance criteria.
Shelter Temperature Device Check	Semi-annual	<± 2.1°C of standard	EPA QA Handbook Vol. II ⁹ , Sec 7.2.2	Flag data for which temperature range are outside of acceptance criteria.

Table 9. Systematic Criteria for NO_x/NO_y Analyzers

Requirement	Frequency	Acceptance Criteria	Reference	Action
Sample Residence Time	Annually	≤20 seconds	40 CFR Part 58, App. E Sec. 9(c) ²	Adjust flow rate so that residence time is under 20 seconds.
Precision (using 1-point QC checks)	Calculated Annually and as appropriate for design value estimates	90% CL CV <15.1%	1) 40 CFR Part 58 App A 2.3.1.2 & 3.1.1 2) 40 CFR Part 58 App A Sec. 4 (b) 3) 40 CFR Part 58 App A Sec. 4.1.2	-
Bias (using 1-point QC checks)	Calculated annually and as appropriate for design value estimates	95% CL ≤ ±15.1%	1) 40 CFR Part 58 App A 2.3.1.2 & 3.1.1 2) 40 CFR Part 58 App A Sec. 4 (b) 3) 40 CFR Part 58 App A Sec. 4.1.3	-
Completeness	Annual standard	≥75% hours in a year	40 CFR Part 50, App. S Section 3.1(b) ⁹	-
	1 hour standard	1) 3 consecutive calendar years of complete data 2) 4 quarters complete each year 3) ≥75% of sampling days in a quarter 4) ≥75% of hours in a day	40 CFR Part 50 App. S Section 3.2 ⁹	-

14.2 Visual Inspection of Equipment

The Site Operator visits the shelter monthly, or as often as weather permits, to check that the analyzers are operational and recording concentrations typical for the environment. At this time, the Site Operator will inspect the shelter temperature and adjust the thermostat, if necessary.

14.3 Remote Interrogation of Monitoring Station and Inspection of Data

The DAS at the monitoring stations will be interrogated daily via an internet connection to download and process the data. Abnormal data values or problems will be reported as soon as possible to the Contractor, who will initiate corrective action and determine if a special site visit is required.

Computerized inspection and visual inspection of these data will be performed daily using an outlier program. Values that fall outside of prescribed limits (**Tables 7-9**) will be evaluated by the Contractor and Project Manager and corrections to data will be documented.

14.4 Equipment Calibration

NO_x/NO_y analyzers will be calibrated quarterly (i.e., multipoint calibration), when changes are made to the analyzer, or when problems require it. All MFC flow rates will be verified quarterly with a NIST traceable flow standard.

14.5 Calibration Reference Standard Certification

NIST traceable NO/NO_x compressed cylinders will be purchased from reputable vendors who can provide NIST traceability for their gases. Only NIST-certified vendors will be used. All gases are stored in aluminum cylinders and are shipped back to the vendor before the gas standard date lapses. See the SOP for NO_x/NO_y analyzers for the calibration procedures.

14.6 Zero and Span Checks

Quality control procedures include zero and span checks every three days. The analyzers are challenged using NIST Traceable gases blended with zero air within the multi-gas dilution calibrator. See the SOP for NO_x/NO_y analyzers for the zero and span check procedures.

14.7 One-point QC Checks

One-point QC checks or precision checks of the NO_x/NO_y analyzers will consist of a one-point check performed immediately following the zero/span checks every three days. These precision checks will be conducted by challenging the analyzers with a standard gas at a known concentration. These precision checks will be done in conjunction with the zero/span checks but done prior to any zero or span adjustments performed as part of those checks. The concentration of the NO or NO₂ used for these checks will be approximately 8 to 10 % of the Upper Range Limit for NO_x/NO_y analyzer. See the SOP for NO_x/NO_y analyzers for the one-point QC check procedure.

15.0 Equipment Maintenance

The manufacturer's recommendations for maintenance will be followed. Analyzer/Instrument manuals are available at the site for reference of preventive and remedial maintenance procedures. Preventive and corrective maintenance will be documented on the calibration forms completed immediately after any maintenance. See Section 16.3 for the instrument and equipment maintenance procedures.

The table below (**Table 10**) illustrates the systematic criteria and references for the support equipment, siting and reporting units for the NO_x/NO_y monitoring network.

Table 10. Systematic Criteria for NO_x/NO_y Analyzers Support Equipment

Requirement	Frequency	Acceptance Criteria	Reference
Sample Probe (NO _x)	---	Borosilicate glass (e.g. Pyrex) or Teflon	40 CFR Part 58 Appendix E Section 9 ²
Sample Probe (NO _y)	---	External Teflon line connected to Stainless Steel faced solenoid interfaced with Molycon. All sample lines from Molycon to reaction chamber are Teflon.	---
Siting	1/year	Meets siting criteria	40 CFR Part 58 Appendix E ²
Reporting Units		ppb for both WyVisNet and AQS	

16.0 Instrument Equipment Testing, and Inspection

16.1 Acceptance Testing of Instrumentation and Equipment Integration

Prior to installation, all equipment will be visually inspected to ensure there is no physical damage. Acceptance testing of instrumentation will be performed to verify that the equipment meets the required US EPA performance specifications. NO_x/NO_y analyzers that fail to meet specifications will be returned to the manufacturer. After installation, the analyzers are calibrated according to the SOP for NO_x/NO_y analyzers. Preventive maintenance will be performed as per Section 16.3 of this QAPP. QC procedures will be conducted on a routine basis, as described in the SOP for NO_x/NO_y analyzers.

To ensure that the analyzers are operating properly, periodic performance audits are conducted by the WDEQ-AQD. This is described in Section 20 of this QAPP and the SOP for performance evaluations of gaseous analyzers.

16.2 Site Surveillance and System Check Procedures

The Site Operator will visit the monitoring station (monthly) to inspect the monitoring equipment. The primary Site Operator will conduct monthly flow checks, filter exchanges, and will perform any maintenance that is required. The Site Operator will also verify proper operation of the DAS, zero air system and calibration system.

During each site visit, entries will be made in the site or electronic logbook (E-log) documenting all site activities conducted. These entries will include the date of the visit, reason for the visit, and the maintenance or calibration activities performed. If changes are made to the equipment or configuration of the system, these changes will also be entered in the site logbook. Entries will be made any time there is a change or modification in the way a sample is obtained, or the station configuration altered. If the Site Operator encounters a problem which cannot be rectified, he/she will contact the Contractor, who will be responsible for resolving the issue. The Contractor will initiate a plan for corrective action and, upon approval of the Project Manager, will employ whatever resources are required to rectify the situation.

Entries to the site logbook will be made when: (1) tubing is re-routed or new fittings or other components are added or removed in any stream of sample air or calibration gas between analyzers, dilution calibrator, or sampling ports on the sampling tubing or station manifold, (2) the relative position of the analyzer's sample ports on the manifold or tubing is changed, (3) a new blower is added or a pump in an analyzer is replaced, (4) the location of a sampling inlet or port is moved, or (5) any similar change in the air monitoring station's configuration.

16.3 Site and Equipment Maintenance

The manufacturer's recommendations for maintenance of the analyzers will be followed. Instrument manuals are available to reference preventive and remedial maintenance procedures. Preventive and corrective maintenance will be documented on the calibration forms completed immediately after any maintenance. The Teflon intake sample lines are checked for cracks or leakage and are replaced, as

necessary. See **Table 11** and **Table 12** for site and equipment maintenance activities and frequencies.

Table 11. Site Maintenance Activities

Maintenance Activity	Frequency
Sample intake manifold cleaning	Monthly or as needed
Sample inlet tubing replacement	Annually or as needed
Monitoring shelter floor cleaning	Monthly or as needed
Monitoring shelter trash removal	As needed
Monitoring shelter light bulb replacement	As needed
Heating/AC system filter replacement	As needed
Main sample intake filter	Monthly or as needed

Table 12. Equipment Maintenance Activities

Maintenance Activity	Frequency
NO_x/NO_y Analyzer	
Verify test functions	Monthly or as needed
Particulate filter replacement	Quarterly or as needed
NO ₂ converter efficiency check	Quarterly
External dryer option chemical replacement	When indicator changes color
Ozone cleanser chemical change	Annually or as needed
Reaction cell window cleaning	As needed
DFU filter on dryer and pump replacement	Annually or as needed
Leak check	Every 6 months or as needed
Reaction cell and O ₃ sintered filters and O-ring replacement	Annually or as needed
Rebuild pump	When RCEL pressure exceeds 10 in. Hg
Inline exhaust scrubber replacement	Annually or as needed
NO ₂ converter replacement	Every 3 years or as needed
Desiccant bag replacement	Anytime PMT housing is opened
Ozone flow	As needed
Ozone dryer filter-DFU	Replace annually or as needed
Sample flow	As needed
Pneumatic lines	Every 3 months or as needed
Dilution Calibrator	
Verify Test Functions	After maintenance or repair
Perform Flow Check	Quarterly or as needed
Perform Leak Check	Annually or after maintenance
Examine Pneumatic Lines	Quarterly or as needed

Maintenance Activity	Frequency
Zero Air System	
Check tubing	Quarterly or as needed
Replace charcoal scrubber	Annually
Replace purafil	Annually
Replace HC scrubber	When contaminated
Replace regenerative dryer	When contaminated
Replace particulate filter on rear panel	Annually
Replace 4-way valve	Annually or as needed

17.0 Inspection/Acceptance of Supplies and Consumables

17.1 Spare Parts

Spare parts for the NO_x/NO_y analyzers will be stored in the monitoring shelter and will be used as needed. These spare parts include, but are not limited to, pump re-build kits, Teflon sample filters, zero air scrubber material, various O-rings and IR light source. Any additional parts that are not stored at the monitoring station will be stored at the WDEQ-AQD and contractors' central operating facilities.

17.2 Inspection/Acceptance of Supplies and Consumables

Spare parts will be purchased only from the instrumentation manufacturer by the Contractor or Project Manager. Parts will be inspected by the Contractor, Project Manager or Site Operator for shipping damage upon receipt. Spare parts will be kept in the monitoring shelter for use when needed. The use of spare parts will be documented on calibration forms.

The NO_x/NO_y analyzers, dilution calibrator, and zero-air system use inlet filters, Purafil, charcoal and span gas that do not require acceptance testing. Inlet filters are replaced by the Site Operator approximately every month. The Purafil and charcoal are replaced annually or more frequently, as needed.

18.0 Non-Direct Measurements

The data collected from the NO_x/NO_y monitoring program are used for NAAQS and WAAQS non-attainment decisions, compliance, dispersion modeling, and/or comparison with other ambient air monitoring data. The current NAAQS and WAAQS for Nitrogen Dioxide are a 1-hour and annual standard set at 100 ppb and 53 ppb (annual average), respectively. See **Table 2** which illustrates the NO₂ standards (primary or secondary), averaging time, level and form.

19.0 Data Management

The proper management of all data is critical to assuring the quality and usability of the monitoring results. As such, procedures have been implemented to ensure robust data acquisition, validation, reduction, reporting, and storage of electronic data. NO_x/NO_y data will be recorded and stored on-site DAS. Data will be retrieved from the monitoring site daily via internet connection. The monitoring site can be called from any computer having the correct software and the IP address.

All electronic calculations and statistical analyses will be performed using standard software that can be easily verified. All project documentation, records, data, and reports will be stored for at least five (5) years following project completion. The data are stored on the WDEQ-AQD network servers once it is reported to AQS and will be archived at a separate location.

NO_x/NO_y data will be reviewed routinely by the Contractor and Project Manager assigned to the monitoring station. These data will be subjected to several levels of QC, validation and QA. Validated data are compiled into the final database for further analysis and report preparation. The final database is processed and stored on a personal computer and then archived on various storage media and maintained in duplicate in more than one location for protection. For more details, please see Sections 21 and 22.

19.1 Data Retrieval

Data are retrieved from the site by connecting to the DAS via remote telemetry. In the past, WDEQ-AQD did not house the raw data. The data were housed and validated data by the Contractors. Recently, the WDEQ-AQD changed over to the AirVision platform also known as WyVisNet. This is a WDEQ-AQD housed data storage system that will be accessible to both Contractors and WDEQ-AQD staff. For the SLAMs stations (PM), the WDEQ-AQD data will housed in AirVision system and the WDEQ-AQD staff will perform validation on the data. For our SPM/gaseous stations, the Contractors will be the primary data repository.

19.2 Raw Data

Raw data are records, notes, memoranda, worksheets or exact copies and are the result of original observations and activities of the monitoring project. Raw data include data from the DAS and data entered directly into a system.

19.3 Data Transfer

The analyzer produces digital and analog voltages that are collected by a DAS and averaged over a particular time period. The data are stored on a network and are validated quarterly. The hourly data are uploaded to WyVisNet every 15 minutes.

19.4 DAS Data Review

Data review is performed by the Contractor. The review of data includes reviewing the calibration

information, zero/span/one-point QC checks, flow checks, maintenance logs, hourly data, flags, and recording any information that might be vital to proper review of the data. Information used in the review may be used to invalidate data.

It is recommended that the Contractor follow a checklist when reviewing. This list should provide a reminder for the reviewer to verify missing data periods, percent data recovery, or data table calculations, to name a few. Data review also includes documentation of suspect data or invalidations that occurred.

19.5 Data Validation

Data validation ensures that data processing operations have been carried out correctly and that the field operations have been performed properly and in accordance with written procedures. Once data validation has identified problems, the data can be corrected, flagged, or invalidated and corrective actions can be taken when necessary. In the event of a failed audit or out of range calibration, the Contractor and Project Manager will be responsible for checking or invalidating data. Data validation procedures are described in detail in Section 22.

19.6 Data Transmittal

Data transmittal occurs when data are transferred from one location to another or from one person or group to another. An example of data transfer is the electronic transfer of data over a telephone or computer network. WDEQ-AQD requires that data be prepared in AQS format on a quarterly basis and stored in zip files with a specific name format that incorporates the reported year and quarter.

The Data Manager will report all ambient air quality data and information as specified by the AQS Users Guide and coded in the AQS format. Such data will be fully validated and will be submitted directly to the AQS via electronic transmission.

19.7 Data Processing

Data processing includes the aggregating and summarizing of results so they can be easily understood and interpreted in various ways. EPA regulations require certain summary data be computed and reported on a regular basis such as precision, accuracy, bias, etc.

19.8 Data Analyses

Data summary and analysis requirements, as presented in 40 CFR Part 58, Appendix A², will be followed for this program. Single analyzer accuracy, based on performance audits, single analyzer precision, bias, and data completeness will be tracked and reported for the monitoring network.

19.9 Data Flagging

Data will be flagged if a numeric result was available but has been qualified in some respect related to the validity of the result. Null data codes will be generated for invalid data as they are entered into the AQS database.

An exceptional event, as defined in 40 CFR Part 50.1 (j)¹⁰, provides that an exceptional event is one that affects air quality, is not reasonably controllable or preventable, and is caused by human activity that is unlikely to recur at a particular location or a natural event. Additional requirements in 40 CFR Part 50.14¹¹ (1) (2) and (b) (1) identify that a state must demonstrate a “clean and casual relationship between the measured exceedances or violation of such standard and the event” and that “an exceptional event caused a specific air pollution concentration in excess of one or more National Ambient Air Quality Standards.” Thus, WDEQ-AQD and the Contractors will flag data related to an exceptional event at the request of the WDEQ-AQD. Electronic copies of the data will be stored at WDEQ-AQD office in Cheyenne, Wyoming.

19.10 Data Submittal to AQS

Each quarter, the Contractor will prepare and submit the files containing observed data that are ready for AQS upload (“RD” transaction) to WDEQ-AQD’s IMPACT system. These files are prepared from validated hourly data and conform to the EPA’s central database – the Air Quality System (AQS) coding guidelines found on the AQS website¹². Missing data will carry the null code that best describes the reason for each missing data point. The most common reasons for missing data include zero, one-point QC, and span checks, calibration, maintenance, audit, and power outage.

Data may also be marked with a qualifier code to denote suspect data if necessary. Data in the AQS files may be reported in standard or alternative units, which are defined by AQS. Criteria pollutants will be reported in a manner consistent with guidelines set forth in the Appendices of 40 CFR Part 50. For details on WDEQ-AQD AQS coding, please see Appendix B, Section 3.0.

Section C. Assessment and Oversight

20.0 Assessment and Response Actions

The WDEQ-AQD QA Coordinator will perform the quarterly (Cheyenne NCore and Boulder) and semi-annual (SPMS) performance audits on the NO_x/NO_y analyzers. Audit procedures and techniques followed by the WDEQ-AQD are established per EPA audit guidelines.

Performance audits are attended by a Contractor Representative and the QA Coordinator. The auditor will use the on-site logbook to record the times and parameters audited, as well as any witnesses to the audit. Electronic documentation of audit results will be kept for a period of five years following the audit. Audit summaries are available on WDEQ-AQD's IMPACT system. WDEQ-AQD is responsible for inputting audit results in EPA's AQS system.

On November 10, 2010, EPA published a memo which expanded the audit levels for the gaseous pollutant annual performance evaluations to ten levels so as to better reflect the spread of the routine ambient air data being collected. **Table 13** presents these values below:

Table 13. NO₂ Audit Levels

Audit Level	NO ₂ Concentration Range (PPM)
1	0.0003 – 0.0029
2	0.0030 – 0.0049
3	0.0050 – 0.0079
4	0.0080 – 0.0199
5	0.0200 – 0.0499
6	0.0500 – 0.0999
7	0.1000 – 0.2999
8	0.3000 – 0.4999
9	0.5000 – 0.7999
10	0.8000 – 1.000

The March 27, 2016 Federal Register provided the final rule for the quality assurance changes in both 40 CFR Part 58 Appendix A and Appendix B². One part of the revised rule was the selection of the audit levels for Annual Performance Evaluations. This revision states: "one-point must be within two to three times the method detection limit of the instruments within the Primary Quality Assurance Organizations (PQAOs) network, the second point will be less than or equal to the 99th percentile of the data at the site or the network of sites in the PQAO or the next highest audit concentration level. The third point can be around the primary NAAQS or the highest 3-year concentration at the site or the network of sites in the PQAO." An additional 4th level is encouraged for those agencies that would like to confirm the monitors' linearity at the higher end of the operational range. The WDEQ-AQD auditor will select at least three audit levels that best reflect the measured concentrations at the station.

The EPA or its designee will perform TTP audits of the gaseous instruments within the WDEQ-AQD network according to 40 CFR Part 58². The NPAP TTP audits are an integral part of an ambient air

monitoring program quality system and serve as an independent and objective assessments of data quality and data comparability. NPAP TTP audits may be performed at any time during the contract period. The TTP consists of the EPA or designee setting up independent dilution calibrators, analyzers, gas cylinders, tubing and associated hardware to generate concentrations of gases within the range of the instrument. The TTP output gas will be placed within the inlet probe and flood the inlet, manifold, and all tubing to the instruments. The total flow of the TTP audit must be greater than the total flow of the monitoring inlet system. The TTP designee will then generate concentrations of gas within the range as stated in the previous paragraph and within the ranges described in **Table 13**.

20.1 Data Quality Audits

Data review is conducted daily utilizing electronic and visual scanning to identify outliers and determine whether data are reasonable and representative. The systems audit includes a confirmation of the integrity of transmitted data from sensor outputs to data reporting.

20.2 Corrective Actions

All deficiencies identified during routine data surveillance, performance audits and/or site surveillances will be documented and reported to the Project Manager and Contractor no later than one working day of discovery and, depending on the nature of the deficiency, corrective action will be made no later than seven (7) business days of the notification. Corrective actions to deficiencies will be addressed and documented in the station logbook and on a corrective action report. Follow-up action shall be taken to verify implementation of the corrective action. A corrective action report form will be filled out that identified the problem or deficiency, the proposed corrective action, and the results of the corrective action. Corrective action reports will also be included in the station's quarterly summary report. An example of a corrective action report is presented in Appendix A, the SOP for NO_x/NO_y analyzers. WDEQ-AQD has the authority to issue stop work orders to the Contractors, if necessary.

20.3 QAPP Revisions

If revisions to the QAPPs are needed, any modifications will be performed or approved by the WDEQ-AQD. QAPP reviews will be performed annually by WDEQ-AQD.

21.0 Reports to Management

A summary of the reports to be generated is presented in **Table 14**. The Contractor will generate reports to management.

Table 14. Reports to Management

Reports	Frequency	Content	Responsible Individual	Distribution
Quarterly Reports (Includes Precision and Accuracy)	Quarterly	Summarize Data for Quarterly Summaries	Contractor	See Section 3 Distribution List
Annual Report	Annually	Summarize data for Annual Reports	Contractor	See Section 3 Distribution List
Email notification of Action Limit reached	As Needed	Discuss instrument issues, ZPS level/percentage, and proposed course of action	Contractor	Project Manager
Corrective Action Reports	As Needed	Summarizes Corrective Actions Taken to return the Monitoring Station into compliant status	Contractor	See Section 3 Distribution List
Response to Corrective Action Reports	As Needed	Reports the results of the Corrective Actions Taken	Contractor	See Section 3 Distribution List
Elevated Pollutant Concentration Notification	As Needed	Report of pollutant concentration > than predetermined threshold	Contractor	WDEQ-AQD Monitoring Supervisor, Project Manager, Data Manager

Quarterly reports will be submitted to the WDEQ-AQD within 60 days of the end of the monitoring quarter. The annual report will be submitted to the WDEQ-AQD within 90 days of the end of the monitoring year. Corrective action reports are submitted as needed within seven (7) business days of identifying a deficiency and in the quarterly report.

A notification will be submitted to the WDEQ-AQD Monitoring Supervisor, Project Manager and Data Manager whenever pollutant concentrations measured at the site NO_x/NO_y exceed 100 ppb in an hourly average. Notifications via e-mail will be sent the following business day and will include a graph of the data (including meteorological parameters) from the day the elevated value occurred, along with a brief explanation of the event.

Section D. Data Validation and Usability

22.0 Data Review, Validation, and Verification Requirements

The data validation criteria are based on US EPA's Quality Assurance Handbook for Air Pollution Measurement Systems, Volume II⁴. The data criteria tables, which are detailed in **Table 7**, **Table 8**, **Table 9**, and **Table 10**, are based on the validation templates in EPA's QA Handbook Volume II⁴, Appendix D. **Table 7**, **Table 8**, **Table 9**, and **Table 10** are comprised of critical, operational and systematic criteria that are important to the maintenance of the NO_x/NO_y analyzers. Data that do not meet each and every criterion on the critical criteria table (**Table 7**) should be invalidated unless there is a compelling justification for not doing so. Violation of a criterion on the operational criteria (**Table 8**) table may be cause for invalidation and the reason for not meeting the criterion must be investigated, mitigated, or justified. If a criterion on the systematic criteria table (**Table 9** and **Table 10**) are not met, it does not invalidate these data but may impact the "error rate associated with the attainment/nonattainment decision."

The Project Managers, Contractors and Site Operators are responsible for verifying proper operation of the monitoring equipment under their control. The Contractor will review the incoming data to the standards discussed in this document. During each quarter, the data will be reviewed again by the Project Manager to ensure that the data are complete, accurate, and representative and that erroneous data have been removed in preparation for the final data report.

The Contractor will routinely check for irregularities during the daily data review. Data review includes evaluation of the raw data, three day zero/span/one-point QC (precision) checks, monthly flow checks, maintenance records, calibration and audit data. Any abnormalities in the data will be flagged and noted on the appropriate checklists. Any suspect data will be brought to the attention of the Project Manager as soon as possible. All other documentation pertaining to the project (i.e. station logs, field notes, calibration and audit sheets) will be reviewed to insure that erroneous data are identified and removed, as necessary from the final data set.

Calibration procedures for the NO_x/NO_y analyzers are discussed in the SOP for NO_x/NO_y analyzers. The data will be considered valid when the system response indicated precision, bias and accuracy goals are being achieved.

22.1 Data Acceptance Limits for NO_x/NO_y

Independent performance audits will be conducted to verify the calibration and maintenance of the analyzers. Audit results will be used to invalidate periods of data when the analyzer was not operating within EPA specifications as discussed in **Table 7**, **Table 8**, **Table 9**, and **Table 10**. Zero/span checks will be conducted to verify the performance of the NO_x/NO_y analyzers every three days.

For the determination of NO_x/NO_y data will be valid and acceptable if the following conditions apply:

- Independent performance audits must meet the following criteria: for audit levels 1 & 2, the absolute difference must be <1.5 ppb or <15.1%, whichever is greater, between analyzer response and audit concentration for NO_x/NO_y. For audit levels 3-10, the absolute difference must be <15.1% between

analyzer response and audit concentration for NO_x/NO_y.

- The analyzer span drift between span intervals does not exceed ± 10.1 percent as determined by the zero/span checks.
- The analyzer zero drift for one zero check interval does not exceed ± 3.1 ppb (24-hour), as determined by the zero/span checks.
- The analyzer zero drift for one zero check interval does not exceed ± 5.1 ppb (24-hr to 14 days), as determined by the zero/span checks.

23.0 Data Validation and Verification Methods

NO_x/NO_y data are stored on DAS loggers as one minute and hourly averages (at a minimum) computed from one-second values. Data validation will be performed on the hourly average data. An hourly average will be computed when at least 45 one-minute averages are available for the hour.

The Project Managers and Contractor are responsible for verifying NO_x/NO_y data by reviewing the zero/span/one-point QC checks, flow checks, calibration records, audit results, and field notes from the Site Operators prior to formal acceptance of these data. Precision and bias calculations will be also be reviewed. The Project Managers will use the criteria tables (**Table 7, Table 8, Table 9, Table 10, and Table 11**) to ensure that the reported data meets the appropriate MQOs.

23.1 Level 0 Data Validation

Level 0 data validation is essentially raw data obtained directly from the data acquisition systems in the field. These data have not received any adjustments for known biases or problems that may have been identified during preventive maintenance checks or audits. Level 0 data validation is accomplished by:

- Collecting data via modem
- Initially screening the daily data for anomalies

Stacked parameter plots will be generated which consist of every data point downloaded since the last site interrogation and reviewed by the Contractor for consistency and possible problems. This redundancy assures that problems that might go unnoticed by the software will always be caught by the reviewer.

To aid in data validation, a password-protected project website will be hosted and updated daily by the Contractor. This will differ from Contractor to Contractor. The site should contain 24-hr meteorological chart graphics, daily minimums, maximums, and averages, QA reports, and wind roses. Historical data should also be accessible. By using this approach, data collection percentages are greatly enhanced and data management personnel can quickly note and resolve any potential instrumentation problems.

23.2 Quality Control Checks for Data Validation

Once data are downloaded via modem, they will be subjected to a series of QC checks by a software package. The software package performs extensive quality control checks of the data, generates a data summary report which lists means, maximums, minimums, time of occurrence, data values which fall outside of prescribed ranges, periods of constant values, and periods of rapid value changes. These criteria may be adjusted as data are collected to more accurately encompass site-specific conditions.

For the air quality parameters, additional data review will be initiated by the following:

- NO_x/NO_y concentrations less than -5 ppb
- 5-minute average NO_x/NO_y concentrations greater than 250 ppb

The QC software is used to generate flags or warnings that the parameter value is outside of a normally acceptable range. The outlier program does not invalidate data or erase file records on the basis of these outlier tests. Raw data files are never modified and are archived. It will be left to the Contractor to review the results of the outlier program in conjunction with the data parameter plots and initiate corrective actions if warranted (site visit or data invalidation).

23.3 Level 1 Data Validation

After the QC software is run, visual inspection of the data are performed to identify suspect data values that warrant further investigation. These values will be flagged.

Per EPA's Quality Assurance Handbook for Air Pollution Measurement Systems, Volume II: Ambient Air Quality Monitoring Program⁴, EPA recommends the use of flags or result qualifiers to identify potential problems with data (or a sample). According to EPA, a flag is an indicator of the fact and the reason that a data value (a) did not produce a numeric result, (b) produced a numeric result but it is qualified in some respect relating to the type or validity of the result, or (c) produced a numeric result but for administrative reasons is not to be reported outside the organization.

Thus, quality control flags and codes, consisting of a letter and value will be assigned to each datum to indicate its quality. Multiple flags will be applied to each invalid data point such as data invalid due to calibration. **Table 15** presents the data flags and codes that will be applied to the data. Additional AQS qualifier codes can be found at:

<https://aqs.epa.gov/aqsweb/documents/codetables/qualifiers.html>

Table 15. Data Flags

Flag	Code	Description
V	0	Valid
C	1	Corrected or Estimated
S	7	Suspect: data appears to be a data spike or outside normal data range
I	8	Invalid data
M	9999	Missing data: measurement not taken
BJ	9963	Operator Error
AC	9969	Construction in Area
AE	9971	Shelter Temperature Outside Limits
AH	9974	Sample Flow Rate Out of Limits
AL	9978	Voided by Operator
AM	9979	Miscellaneous Void
AN	9980	Instrument Malfunction
AP	9982	Vandalism
AQ	9983	Collection Failure
AS	9985	Poor QA Results
AT	9986	Calibration
AV	9988	Power Failure
AW	9989	Wildlife Damage
AX	9990	Precision Check
AY	9991	QA Control Points (Zero/Span)
AZ	9992	QC Audit
BA	9993	Maintenance
BB	9994	Unable to Reach Site
BC	9995	Multi-Point Calibration
BD	9996	Auto Calibration
BF	9998	ZPS

To assist in data validation, a copy of the site logbook and E-logbook will be examined to confirm periods when instrumentation may have been off-line due to power outages, maintenance or repair, audits, or other quality assurance activities. Significant events will be checked against the graphs for consistency.

QC check data will be reviewed to assess the precision and bias of the data. If the QC checks or calibrations indicate invalid or low precision, data values may be invalidated or adjusted as necessary and the appropriate flags will be applied. The results from the remote zero/span/one-point QC checks will also be reviewed to determine if the air quality data should be considered invalid. Especially high values will be checked to be sure that audit or calibration data were not inadvertently included. Suspect data will be reported but flagged as suspect. Missing data will be left missing.

It is important to maintain detailed, accurate records of changes to the data. The justification for all data invalidations will be permanently documented in a data validation summary spreadsheet. Suspect data will also be documented. For reporting purposes, hourly NO_x/NO_y data will be presented. Data below -5 ppb will be invalidated.

23.4 Minimum Acceptable Data Recovery Percentage

To be considered valid, each hour of data must consist of at least 45 minutes (75% of a valid hour) of valid data. The data recovery goal for the NO_x/NO_y data will be at least 90% per quarter for WDEQ-AQD requirements and at least 75% as required by 40 CFR Part 50 (appendix S, section 3(b)).

23.5 Data Report QA Checklist

As part of the data validation process to prepare data for reports, report table content versus data files, missing data, off-line periods, percent data recovery and mathematical calculations are routinely verified.

24.0 Reconciliation with User Requirements

The objective of the NO_x/NO_y monitoring network is to collect data that will provide the necessary information for the WDEQ-AQD to assess whether the DQOs are being met. The NO_x/NO_y data will be used to characterize and monitor trends in air quality, national and state air quality standards and may be used for national health assessments, model evaluations, and comparison with other ambient air monitoring and meteorological data. Following the procedures described in this QAPP and the SOP for NO_x/NO_y analyzers will ensure that the DQOs are met and the data will be representative of air quality conditions and be of acceptable quality for precision, bias and completeness.

References

1. Wyoming Department of Environmental Quality- Air Quality Division Annual Network Plan 2024
<https://drive.google.com/file/d/1BBfIi5gCAdMUbl3uTuwLZMWNYKEyjW9/view>
2. Code of Federal Regulations Title 40 Part 58, Appendices A-E.
<https://www.ecfr.gov/current/title-40/chapter-I/subchapter-C/part-58>
3. Code of Federal Regulations Title 40 Part 50 Appendix F.
<https://www.ecfr.gov/current/title-40/part-50/appendix-Appendix F to Part 50>
4. Quality Assurance Handbook for Air Pollution Measurement Systems: Volume II: Ambient Air Quality Monitoring Program, EPA-454/B-17-001, January 2017,
https://www.epa.gov/sites/default/files/2020-10/documents/final_handbook_document_1_17.pdf
5. Technical Assistance Document For Precursor Gas Measurements in the NCore Multi-Pollutant Monitoring Network, Version 4, EPA-454/R-05-003 September 2005.
<https://nepis.epa.gov/Exe/ZyNET.exe/P100ACLX.TXT?ZyActionD=ZyDocument&Client=EPA&Index=2000+Thru+2005&Docs=&Query=&Time=&EndTime=&SearchMethod=1&TocRestrict=n&Toc=&TocEntry=&QField=&QFieldYear=&QFieldMonth=&QFieldDay=&IntQFieldOp=0&ExtQFieldOp=0&XmlQuery=&File=D%3A%5Czyfiles%5CIndex%20Data%5C00thru05%5CTxt%5C0000027%5CP100ACLX.txt&User=ANONYMOUS&Password=anonymous&SortMethod=h%7C-&MaximumDocuments=1&FuzzyDegree=0&ImageQuality=r75g8/r75g8/x150y150g16/i425&Display=hpfr&DefSeekPage=x&SearchBack=ZyActionL&Back=ZyActionS&BackDesc=Results%20page&MaximumPages=1&ZyEntry=1&SeekPage=x&ZyPURL>
6. EPA's Quality Assurance Handbook for Air Pollution Measurement Systems, Volume I: A Field Guide to Environmental Quality Assurance 1994
<https://www.epa.gov/sites/default/files/2020-10/documents/r94-038a.pdf>
7. Technical Assistance Document for Sampling and Analysis of Ozone Precursors for the Photochemical Assessment Monitoring Stations Program, EPA Document EPA-454/B-19-004, May 2023
<https://www.epa.gov/system/files/documents/2023-05/TAD%20R3%May%202023.pdf>
8. Code of Federal Regulations Title 40 Part 53.23(b).
[https://www.ecfr.gov/current/title-40/part-53#p-53.23\(b\)](https://www.ecfr.gov/current/title-40/part-53#p-53.23(b))
9. Code of Federal Regulations Title 40 Part 50. Appendix S. <https://www.ecfr.gov/current/title-40/part-50/appendix-Appendix S to Part 50>
10. Code of Federal Regulations Title 40 Part 50.1 (j).
[https://www.ecfr.gov/current/title-40/part-50/section-50.1#p-50.1\(j\)](https://www.ecfr.gov/current/title-40/part-50/section-50.1#p-50.1(j))
11. Code of Federal Regulation Title 40 Part 50.14(1).
<https://www.ecfr.gov/current/title-40/section-50.14>
12. AQS Users Guide. <https://www.epa.gov/aqs/aqs-manuals-and-guides>

APPENDIX A: Standard Operating Procedures

Appendix A.1 - Standard Operating Procedures for NO_x and NO_y Analyzers

**Wyoming
Department of
Environmental
Quality – Air Quality
Division**



WYOMING DEPARTMENT OF
ENVIRONMENTAL
QUALITY

Standard Operating Procedure for Oxides of Nitrogen and
Reactive Oxides of Nitrogen Analyzers

**December 2024
Revision 3**

1.0 Scope and Applicability

Oxides of Nitrogen/Reactive Oxides of Nitrogen (NO_x/NO_y) in the atmosphere are a by-product of the incomplete combustion of organic (e.g., gas and petroleum) compounds in the presence of nitrogen. The reason it has a National Ambient Air Quality Standard (NAAQS) associated with it, is that one species is toxic to humans and animals (i.e., Nitrogen Dioxide, NO₂). In addition, NO_x/NO_y compounds play a major role in ozone and fine particulate matter formation. NO₂ NAAQS is codified in the 40 CFR Part 50¹.

The WDEQ-AQD operates standard level NO_x analyzers, and NO_y analyzers and trace level NO_x at the Cheyenne NCore and Boulder stations. The trace level analyzers are capable of measuring background levels of NO_x. The NO_y analyzers, measures NO_x and reactive species of oxygenated nitrogen. All of the analyzers operated by the WDEQ-AQD are rugged, precise, and accurate and must be stable in the low parts per billion (ppb) and in the case of the trace level instrument, parts per trillion (ppt) range.

2.0 Summary of Method

Oxides of nitrogen are released from emission sources primarily as nitric oxide (NO) and to a lesser extent as NO₂. The two species are collectively termed NO_x (NO_x = NO + NO₂). Through atmospheric processes, NO_x is converted to many other inorganic and organic nitrogen oxides, such as:

- Nitrous acid (HONO)
- Nitric acid (HNO₃)
- Peroxyacetyl nitrate (H₃CC(O)OONO₂, or PAN)

Collectively, these three species are known as NO_z. Therefore, the total of all reactive nitrogen species is NO_y, which the EPA recognizes as the sum of NO_x and NO_z (i.e., NO_y = NO_x + NO_z).

In addition to NO₂ being part of the NAAQS and WAAQS, it also plays a critical role in the photochemical production of ozone and fine particulate matter. Accurate measurement of NO₂ concentrations in ambient air are necessary to support the air quality modeling efforts aimed at evaluating and tracking the progress of control strategies for attaining the ozone NAAQS. NO_x/NO_y photometry is a spectrophotometric method that has been in use since the early 1980s and is the preferred method for measuring NO_x.

The NO_x/NO_y analyzers are a self-contained, microprocessor-controlled instrument that is based on the reaction of NO (or NO_y converted species into NO) with ozone in a reaction chamber. The reaction of NO and ozone give off one photon per molecular reaction. This photon is converted into an electrical current by a photomultiplier tube (PMT). The NO_x/NO_y analyzers do not require any laboratory analysis.

NO_x and NO_y instruments work primarily in the same manner, nitric oxide (NO) is shunted into a chamber with ozone and following reaction occurs:

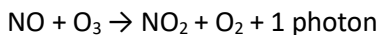

Next to the reaction chamber is a highly sensitive PMT, which is designed to convert the photon to an electron. The circuitry within the instrument counts the number of electrons captured and converts that to a current that is directly related to the concentration of NO in the chamber.

The main difference

between the NO_x and NO_y analyzers is that the NO_y analyzer has an external molybdenum converter (Molycon) that converts all the NO_z species to NO. The NO_x analyzer has an internal Molycon that converts NO_x species to NO. By integrating a solenoid valve switching system, the analyzers measure NO in one cycle and NO_x or NO_y in the other cycle. The analyzer records the data internally and communicates that data to the data acquisition system (DAS).

NO is a stable gas that can be stored in compressed aluminum cylinders. Because of this, cylinders can be filled with known concentrations of NO and shipped to any location. The NO concentrations, if high enough, can be stable in the cylinders for many years. Several gas vendors lease or sell cylinders that are traceable to the National Institute of Standards and Technology (NIST) traceable standards for NO. In this manner, cylinders can be leased of known concentrations and taken to the ambient air monitoring locations throughout the State of Wyoming and can be utilized to calibrate, verify or audit the analyzers in the field.

The NO_x/NO_y network maintained by the WDEQ-AQD is placed in monitoring shelters across the State. The samples are drawn into the instrument as described in Volume II of EPA's Quality Assurance Handbook and Technical Assistance Documents for Measurement Systems^{2,3}. NO_x are measured by sampling ambient air from either a borosilicate glass manifold or sample lines that are made of PTFE or PFA Teflon. For NO_x measurements, the sampling inlet is on the roof of the shelter approximately 4 meters above-ground-level (AGL). The Teflon sampling line or glass manifold is protected by a pipe with a Teflon-coated cover protecting the inlet probe. A Teflon particulate filter also protects the sampling line.

Because the NO_z species that exist in the atmosphere are so reactive, the species must be converted to NO before they enter the monitoring station. As mentioned earlier, the Molycon is mounted externally on top of a 10 meter tower.

The WDEQ-AQD only utilizes FRMs, which have been rigorously challenged by the EPA in the Research Triangle Park, North Carolina laboratory to operate within the parameters set by the EPA. The FRM designation for the WDEQ-AQD NO_x instruments (Teledyne-API T200U) is RFNA-1194-099 and the Thermo instruments, the Thermo 42i, has an EPA designation number of RFNA-1289-074. The NO_y instrument (Teledyne-API T200U) does not have an EPA designation since it does not measure NO₂.

2.1 Definitions

The following terms that are used throughout this document are defined here:

- **NIST:** This acronym refers to the National Institute of Standards and Technology. This is a laboratory in Washington D.C. that creates standards for instruments and materials to government and non- governmental entities and also cooperates with other countries to create international standards. This is performed so that a value of one thing in data collected anywhere in the world or US is comparable to the same information collected somewhere else.
- **NIST Traceability:** this term refers to a “transfer” of a standard or technique that allows the known standardization of one material or instrument to another. In the case of NO_x/NO_y, this is done by using NO gas that has been tested by a NIST traceable instrument and then placed into a compressed gas aluminum cylinder. In addition, the flow rates of the mass flow calibration (MFC) unit from the multi-gas dilution calibrator are also calibrated using NIST traceable flow devices, so that the operator in the field will know what the level of gas that is being delivered to the within a known level of confidence. All NO_x/NO_y instruments within the WDEQ-AQD jurisdiction are NIST traceable.
- **One-point Quality Control (QC) check or Precision check:** This is a one-point check that is performed using a concentration that is usually set in the range where a NO_x/NO_y instrument operates. This check is performed once every three days using the multi-gas dilution calibrator, which generates this point. These values are used for precision and bias calculations.
- **Multi-Gas Dilution Calibrator:** The multi-gas dilution calibrator is an instrument that can precisely control the flow of gases with its mixing chamber. Most dilution calibrators can have several high pressure gas cylinders attached to it and be able to blend those gases with purified air in ratios as low as 1000 to 1. The use of a multi-gas dilution calibrator allows for small amounts of NO/NO_x gas to be blended with large quantities of zero air to get concentrations in the ranges of the instruments. This is a very cost effective way to calibrate the instruments over a long period of time.
- **Gas Phase Titration (GPT):** This term refers to the mixing of two gases that, depending on the concentration, will react to form a third gas. For the sake of the NO_x/NO_y instruments, this refers to the mixing of NO gas with ozone (generated by the multi-gas dilution calibrator) by the following equation:

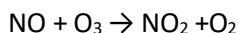

The reaction of NO in the presence of ozone is instantaneous and very stable. By performing this GPT, the Molybdenum converter (Molycon), which is either inside the NO_x instrument or external with regards to the NO_y instrument, can be challenged with NIST traceable gases. Since both the NO gas and ozone generated can be controlled very precisely, it is possible to create a mixture of the NO and NO₂ at different ranges of the instrument being challenged.

3.0 Health and Safety Warnings

The following health and safety warning must be followed in order for safe operation of the instrument.

- NO_x/NO_y instruments generally operate using 110 VAC current. Therefore, if troubleshooting, be extremely cautious against electric shock. This can be both harmful to a person and possibly harm the instrument.
- When generating NO_x/NO_y, be sure to ventilate the working space thoroughly. NIST traceable gas cylinders are often blended with other gases, such as sulfur dioxide (SO₂) and/or carbon monoxide (CO). In addition, since NO_x/NO_y instruments require a GPT, ozone and NO₂ gases are generated as well. If possible, vent all excess calibration outside and avoid breathing it if possible. If you feel dizzy or get a headache when generating NO_x/NO_y gas, get outside or ventilate the indoors immediately.
- Always use a third ground wire on all instruments.
- Always unplug the analyzer when servicing or replacing parts.
- Refer to the manufacturer's instruction manual and know the precise locations of these components before working on the instrument.
- Avoid electrical contact with jewelry. Remove rings, watches, bracelets, and necklaces to prevent electrical burns.

4.0 Cautions

The following precautions must be observed:

- The Molycon operates at high temperatures (approximately 350°). Always allow the instrument to sit for a period of time before performing any repairs to the instrument or the external Molycon that is outside of the shelter.
- Keep the interior of the analyzer clean.
- Inspect the tubing within the instruments regularly for structural integrity.
- To prevent major problems with leaks, make sure that all sampling lines are reconnected after required checks and before leaving the site.

4.2 Interferences

The chemiluminescence method for detecting NO_x/NO_y is subject to interference from a number of sources including certain hydrocarbons, water vapor (H₂O), and ammonia (NH₃). The NO_x and NO_y instruments have been designed to reject most of these interferences when used under normal ambient air conditions. Hydrocarbons are removed by a pre-reactor; water vapor is removed by a Perma-Pure dryer. However, depending on its temperature, the converter may convert a small amount of NH₃ to NO, resulting in increased NO readings. However, under normal ambient air circumstances, NH₃ concentrations are much lower than NO levels and the interference is negligible. Nonetheless, care should be taken when siting the monitor to be sure that it is not located near significant NH₃ sources.

5.0 Personnel Qualifications

It is the responsibility of WDEQ-AQD and/or the Contractor to train their laboratory or field staff on instrument operation and maintenance. It is a requirement of the WDEQ-AQD to train their staff but also keep records of all training that is performed per WDEQ-AQD's Training Plan. Although NO_x/NO_y analyzers are self-contained, computer-operated instruments, there is a level of knowledge of electronics and know-how involved in the operation and maintenance of the instrument. The instrument manual is the best training tool for this.

6.0 Equipment

WDEQ-AQD and its contractors specifically utilize Federal Reference Method (FRM) NO_x instruments, because it is required by the EPA. FRMs are thoroughly vetted by the EPA and when initially received, should operate within the parameters set down by the EPA. These parameters are available in the operating manual that comes with the instrument. Thoroughly read and familiarize yourself with this instrument. NO_y instruments do not measure NO₂ directly, therefore, these instruments do not have an FRM designation. However, the WDEQ-AQD does operate NO_y instruments that have been tested by the EPA and been approved.

The following supplies and equipment are required for the operation of this instrument:

- **Multi-Gas Dilution Calibrator:** As mentioned above, these units blend gases precisely and allow the user to challenge the instruments with gas concentrations of known quantity and accuracy. In addition, the dilution calibrator must have the GPT function built into the unit.
- **NIST traceable NO cylinder:** Numerous vendors can provide stable, NIST traceable NO cylinders with concentrations that can be periodically verified by the vendor.
- **Zero Air Generator:** Zero air is required for the calibration of NO_x/NO_y instruments. This air must be NO/NO_x-free to 0.001 ppb or 0.0001 ppb for trace level and be free of water vapor.
- **Output Manifold:** The manifolds at all stations are constructed out of borosilicate glass or Teflon lines.
- **Tubing and Fittings:** Teflon is an inert material that is used exclusively throughout the system. All fittings and ferrules must also be made of PFA or PTFE Teflon.
- **In-Line Filters:** These are used to filter out particulate matter and water vapor in the inlet side of the tubing. These should be changed on a periodic basis.

Spare parts for the NO_x/NO_y analyzers will be stored in the monitoring shelter and will be used as needed. These spare parts include, but are not limited to, pump re-build kits, zero air scrubber material, various o-rings, Teflon and stainless steel fittings and PTFE 47 mm filters.

6.1 Inspection/Acceptance of Supplies and Consumables

Spare parts will be purchased only from the instrumentation manufacturer by the Project Managers or the Contractors. For the WEDQ-AQD operated sites; parts will be inspected by the Project Managers, Contractors or Site Operators for shipping damage upon receipt. Spare parts will be kept in the monitoring shelter for use when needed. Please note that some parts will be stored at the monitoring stations while some less utilized parts will be stored at the Contractors' and/or WEQD-AQD's central facilities. The AQD will use AirVision software to track spare analyzer usage.

The NO_x/NO_y analyzers, the multi-gas dilution calibrator, gas cylinders, and zero-air system use inlet filters, Purafil, charcoal, and span gas, and supplies do not require acceptance testing. Inlet filters are replaced by the Site Operator at each monthly site visit or as necessary. The Purafil and charcoal is replaced yearly or more frequently, as needed.

7.0 Quality Control Procedures

At this time, the National transfer of traceability for NO_x/NO_y is detailed in EPA's Quality Assurance Handbook Volume II². The procedures in this document describe in-depth how the traceability to NIST standards is accomplished. In addition, another document, "Standard Operating Procedures for the Teledyne-Advanced Pollution Instrumentation Model 200EU Ultra-Sensitive NO/NO₂/NO_y Analyzer with Model 501Y Converter", May 6, 2009⁴, version 2.0 is also referenced in the writing of this SOP.

Table 1. NO_x/NO_y Instrument QC Procedures

Procedure	Frequency	Requirement
Visual Inspection of Equipment	Each site visit; typically once a month	As needed
Remote interrogation of the monitoring station and inspection of data	Daily	QC checks for data screening
Calibration	Quarterly	Meets MQO
Cylinder Certification	Depending on the mixture of gases in the cylinder, once every three years (specified on the Certificate of Analysis).	Ship the cylinder to the gas vendor for recertification to NIST Traceable Standards.
Zero/span checks	Once every 3 days	Meets MQO
Precision checks	Once every 3 days	Meets MQO
Equipment Maintenance	As needed or as the operating manual recommends	See SOP and instrument manuals
In-line filter change	Each site visit; typically once a month	As needed

The identification, cause, and corrective action for conditions adverse to quality will be documented on the Corrective Action Report form (example in Appendix A of this SOP). Follow-up action will be taken by the Project Manager to verify the corrective action was taken.

7.1 Equipment Maintenance

Tables 2 and 3 illustrate the maintenance schedule that should be followed in order to maintain the instruments in good working order.

Table 2. Station Maintenance Activities

Maintenance Activity	Frequency
Sample intake manifold cleaning	Monthly or as needed
Sample inlet tubing replacement	Annually or as needed
Monitoring shelter floor cleaning	Monthly or as needed
Monitoring shelter trash removal	As needed
Monitoring shelter light bulb replacement	As needed
Heating/AC system filter replacement	As needed
Main sample intake filter	Quarterly or as needed

Table 3. Equipment Maintenance Activities

Maintenance Activity	Frequency
NO_x/NO_y Analyzer	
Verify test functions	Monthly or as needed
Particulate filter replacement	Quarterly or as needed
NO ₂ converter efficiency check	Quarterly
External dryer option chemical replacement	When indicator changes color
Ozone cleanser chemical change	Annually or as needed
Reaction cell window cleaning	As needed
DFU filter on dryer and pump replacement	Annually or as needed
Leak check	Every 6 months or as needed
Reaction cell and O ₃ sintered filters and O-ring replacement	Annually or as needed
Rebuild pump	When RCEL pressure exceeds 10 in. Hg
Inline exhaust scrubber replacement	Annually or as needed
NO ₂ converter replacement	Every 3 years or as needed
Desiccant bag replacement	Anytime PMT housing is opened
Ozone flow	As needed
Ozone dryer filter-DFU	Replace annually or as needed
Sample flow	As needed
Pneumatic lines	Every 3 months or as needed

Dilution Calibrator	
Verify Test Functions	After maintenance or repair
Perform Flow Check	Quarterly or as needed
Perform Leak Check	Annually or after maintenance
Examine Pneumatic Lines	Quarterly or as needed

7.2 Particulate Filter Replacement

Particulate Matter (PM), i.e., dust and pollen, can be drawn into the station inlets and travel through the lines and can enter the NO_x/NO_y instrument's reaction chamber. If this happens, the PM can absorb light and attenuate the photons used to measure NO_x/NO_y. PM filters are placed in-line and remove the PM. Below is a procedure to replace the filters. In the case of the NO_y instrument, the filter holder is on the intake side of the Molycon housing. Before replacing the filter, the Site Operator must gain access to the housing. This is done by lowering the housing so that it can be accessed from the ground.

1. Before proceeding, the NO_x/NO_y channel must be flagged. The Site Operator will follow the site specific procedures to flag the appropriate data channels based on the task being performed.
2. Open the PM filter holder. This is usually behind the instrument and near the inlet to the instrument.
3. Carefully remove the old filter. Examine it for pin holes and any tears in the material. Discard the old filter. At this time, be sure to inspect the O-ring and filter holder rings to make sure the O-ring has not been pinched.
4. Carefully place a new filter into the filter holder and close the unit. If the filter holder is a screw type, do not over-tighten; this can cause the filter to tear.
5. If no check or calibrations are to be performed, then return the NO_x/NO_y instrument channel on the DAS back to data collection status.
6. Enter into the station log (either DataView or OneNote) that a filter change was performed. Note the date and time.

8.0 Automated Zero/Span/Precision Check

The procedure below describes the automated steps that are performed when a zero/span/precision check (ZPS) is initiated by the DAS. This automated check is accomplished by using the site calibration system and the DAS. The multi-gas dilution calibrator is able to generate, measure and deliver known amounts of NO/NO_x to the analyzer at atmospheric pressure. A vent MUST be used in the line somewhere downstream of the analyzer inlet.

1. The automated ZPS is initiated by the DAS to perform a one point QC check from the site calibrator. This value should be in the range of 0.005 to 0.080 ppm for NO₂. The value should be approximately 8 to 10% of the upper range limit (URL) of the instrument.
2. The site calibrator will begin generating the one point QC check by initiating the flow of NO/NO_x gas and zero air to generate a known amount of NO/NO_x.

3. After 10 to 15 minutes, the DAS reads the analyzer response and stores it within the DAS.
4. The DAS will then initiate the NO₂ Precision/QC point, which is performed by introducing ozone into the site calibrator mixing chamber and allowing the instrument to now sample a mixture of NO and NO₂ gases. The DAS will initiate the GPT with the ozone level between 8 and 10% of the analyzer URL.
5. After 10 to 15 minutes, the DAS reads the analyzer response and stores it within the DAS.
6. The DAS switches to zero air. After 10 to 15 minutes the analyzer response is read by the DAS and stored.
7. The DAS will then change the requested NO/NO_x concentration to a set point of 80% of the URL of the instrument.
8. After 10 to 15 minutes, the DAS reads the analyzer response and stores it within the DAS.
9. The DAS will then initiate the NO₂ Span Check, which is performed by introducing ozone into the site calibrator mixing chamber and allowing the instrument to now sample a mixture of NO and NO₂ gases. The DAS will initiate the GPT with the ozone level 80% of the analyzer URL.
10. After 10 to 15 minutes, the DAS reads the response of the instrument and stores that value in the DAS.
11. The DAS then terminates the ZPS and allows the instrument to measure ambient air.

9.0 Instrument Performance Calibrations Procedure

The basic sampling equipment and supplemental supplies that are needed to perform NO_x/NO_y calibrations include: DAS, sampling lines, sampling manifold, NIST traceable cylinder, zero-air source, multi-gas dilution calibrator and record forms.

9.1 Zero Calibration Procedure

1. Before proceeding, the NO_x/NO_y on the DAS must be flagged.
2. Begin by introducing zero air to the sample inlet of the analyzer. This can be accomplished by using the site calibration system or an external zero air source. Zero air or any sample gas must be delivered to the analyzer at atmospheric pressure; therefore, you MUST have a vent in the line somewhere downstream of the analyzer inlet.
 - a. When using the site calibration system, no plumbing changes are required. You simply need to begin by commanding zero air from the site calibrator. The vent is already installed in the system.
3. Wait for the analyzer to reach stability, usually around 10 minutes.

4. Press CAL then ZERO then ENTER to set the new zero level. If you decide you do not want to set the zero, press EXIT instead of ENTER.
5. Press EXIT after ENTER to leave the CAL menu.

9.2 Span Calibration

1. If not already flagged, flag the NO_x/NO_y channel on the DAS.
2. Just as with the zero, the site calibration system can be used or an external span gas source can be used.
3. Begin delivering NO at 85- 90% of the URL of the analyzer whether it is a trace instrument or not. While awaiting system stabilization, set the EXPECTED span gas concentration into the analyzer.
 - a. Press CAL then SPAN. From there, you can enter the span value you are expecting for NO and NO_x/NO_y. NO₂ should remain near zero.
 - b. Set the span value by pressing the buttons corresponding to each digit on the screen to change the value. This changes the actual analyzer internal slope and forces it to read at the previously set SPAN value.
 - c. Press ENTER to store the expected span value.
 - d. While still delivering the 85 - 90% URL gas concentration, and once stabilization has been reached, record the NO, NO₂ and NO_x/NO_y values onto the calibration form.
4. At this time, a GPT point needs to be generated. Using the same NO gas concentration as above (step 3), initiate the GPT point and adjust the ozone concentration to approximately 70 - 80% of the URL of the instrument for NO₂. Allow the instrument to stabilize for 10 to 15 minutes. Record the NO, NO₂ and NO_x/NO_y response on the data sheet.
5. Using the same NO gas concentration as above (step 3), adjust the ozone concentration to approximately 40 - 50% of the URL of the instrument for NO₂. Allow the instrument to stabilize for 10 to 15 minutes. Record the NO, NO₂ and NO_x/NO_y response on the data sheet.
6. Using the same NO gas concentration as above (step 3), adjust the ozone concentration to approximately 8 - 10% of the URL of the instrument for NO₂. Allow the instrument to stabilize for 10 to 15 minutes. Record the NO, NO₂ and NO_x/NO_y response on the data sheet. The NO₂ multipoint calibration has been finished. It is now time to perform the NO multipoint calibration.
7. Press the GEN → AUTO button on dilution calibrator and enter a NO gas value of 40 – 50% of the URL of the analyzer. Allow several minutes for the ozone to be flushed from the system. The NO₂ should drop to around zero. Allow the instrument to stabilize to this point and record NO and NO_x/NO_y. NO₂ should remain zero.

8. Adjust the NO gas concentration to 8 - 10% of the URL of the analyzer. Allow the instrument to stabilize to this point and record NO and NO_x/NO_y. NO₂ should remain zero. The NO and NO_x/NO_y multipoint is now completed.
9. Press STBY on the dilution calibrator and allow 10 -15 minutes for stabilization. After stabilization, return the DAS channel to online.
10. Plot the analyzer responses versus the corresponding calculated concentrations to obtain the calibration relationships. Determine the straight line of best fit ($y=mx+b$) determined by the method of least squares. This should be done for NO, NO₂ and NO_x/NO_y. Remember the NO₂ source value is NO_x/NO_y-NO response at each point. Also at this time, calculate the Molycon converter efficiency. The details on how to perform this calculation is written in the operator's manual. This value should not be lower than 96%. If this value falls below this QC limit, then the Molycon should be replaced.
11. After the best fit line has been drawn, determine whether the analyzer response is linear. To be considered linear, no calibration test point should differ from the best-fit line by more than 2.1% of full scale.

9.3 Method Detection Limit Test

The Method Detection Limit (MDL) is the lowest concentration of a substance that can be reliably determined (99% confidence) by a given procedure. Any measurement falling at or above the MDL reflects a concentration that is significantly different from zero at a 1% percent false positive rate. The Lower Detection Limit (LDL) should be 0.050 ppb (50 ppt) of NO_x/NO_y or lower for the trace level instrument⁴. The operational MDL is not given by manufacturing. The vendors' advertised LDL, which is defined as the minimum concentration that produces a signal that is twice the noise level. The LDL can be estimated by sampling zero air and estimating the noise level according to 40 CFR 53.23 (b)⁷. The EPA specifies that the MDL must be established at the time the instrument is being brought online for data collection.

This is accomplished by supplying the analyzer at least seven times with a test atmosphere of trace level NO_x/NO_y. The Trace Level instrument at an NCore site will have an initial MDL determined and subsequent MDL determinations performed annually thereafter.

The MDL determination will be performed as follows:

1. Determine the concentration of the challenge gas to be introduced to the analyzer. This is defined as a value that is 2.5 to 5 times the noise as provided by the manufacturer (see instrument manual). Since this is a MDL, the gases should be introduced at the sample inlet.
2. Establish and set the instrument "zero" using a source of pollutant-free air. This is performed immediately prior to performing the MDL and can be associated with an instrument.

3. Please note that no adjustments to the instrument are allowed during the MDL study. If adjustments or maintenance is required for routine data collected, the MDL determination must be restarted.
4. Introduce the challenge gas to the analyzer through the sample inlet port for a time sufficient to allow the readings to stabilize plus at least 30 additional minutes.
5. Collect, record, and calculate the average of the last 20 sixty-second averages using a spreadsheet such as Excel. This will be data point number one.
6. A minimum of seven data sets is required. Repeat steps 2 - 5 above for 6 additional days. This will result in seven data points.
7. If the instrument is in service for ambient data collection, these events should be scheduled such that they do not interfere with other calibration check activities.

Calculate the MDL test as outlined in Reference 4.

10.0 References

1. QA Handbook for Air Pollution Measurement Systems: Volume II: Ambient Air Quality Monitoring Program, January 2017, https://www.epa.gov/sites/default/files/2020-10/documents/final_handbook_document_1_17.pdf
2. Technical Assistance Document For Precursor Gas Measurements in the NCore Multi-Pollutant Monitoring Network, Version 4, EPA-454/R-05-003 September 2005
<https://nepis.epa.gov/Exe/ZyNET.exe/P100ACLX.TXT?ZyActionD=ZyDocument&Client=EPA&Index=2000+Thru+2005&Docs=&Query=&Time=&EndTime=&SearchMethod=1&TocRestrict=n&Toc=&TocEntry=&QField=&QFieldYear=&QFieldMonth=&QFieldDay=&IntQFieldOp=0&ExtQFieldOp=0&XmlQuery=&File=D%3A%5Czyfiles%5CIndex%20Data%5C00thru05%5CTxt%5C0000027%5CP100ACLX.txt&User=ANONYMOUS&Password=anonymous&SortMethod=h%7C-&MaximumDocuments=1&FuzzyDegree=0&ImageQuality=r75g8/r75g8/x150y150g16/i425&Display=hpfr&DefSeekPage=x&SearchBack=ZyActionL&Back=ZyActionS&BackDesc=Results%20page&MaximumPages=1&ZyEntry=1&SeekPage=x&ZyPURL>
3. Standard Operating Procedures for the Teledyne-Advanced Pollution Instrumentation Model 200EU Ultra-Sensitive NO/NO₂/NO_y Analyzer with Model 501Y Converter, May 6, 2009 <https://www3.epa.gov/ttnamti1/files/ambient/pm25/spec/M200EUNOySOP.pdf>
4. Code of Federal Regulations Title 40 Part 50, Appendix F.
[https://www.ecfr.gov/current/title-40/part-50/appendix-Appendix F to Part 50](https://www.ecfr.gov/current/title-40/part-50/appendix-Appendix%20F%20to%20Part%2050)
5. Code of Federal Regulations Title 40 Part 58, Appendix A, section 3.1.1.1. <https://www.ecfr.gov/current/title-40/chapter-I/subchapter-C/part-58#Appendix-A-to-Part-58>
6. Code of Federal Regulations Title 40 Part 53.23 (b).
[https://www.ecfr.gov/current/title-40/part-53#p-53.23\(b\)](https://www.ecfr.gov/current/title-40/part-53#p-53.23(b))

APPENDIX A FORMS

Corrective Action Form Example Contractor NO_x/NO_y Calibration Form Examples

CORRECTIVE ACTION REPORT

PROJECT NAME _____

Identification of a Problem or Deficiency:

Created By: _____
Assigned To: _____
Date: _____

Summary: _____

Corrective Action Taken and Results:

From: _____

Corrective Action Description: _____



NITROGEN OXIDES CALIBRATION SHEET

AS FOUND

SITE NAME _____ **Date** _____ **Start Time** _____
PROJECT _____ **Stop Time** _____
SITE OPERATOR _____

Analyzer Mfg _____ **Anal. Range 0-** 200 **PPB**
Analyzer Model _____
Analyzer s/n _____

CALIBRATION EQUIPMENT:

Calibrator: _____ **Audit Gas:** _____ **Zero Air Source:** _____
Model: _____ **Concentration:** _____ **Model:** _____
Serial #: _____ **Serial #:** _____ **Serial #:** _____
Cert Date: _____ **Certification Date:** _____ **Certification Date:** _____
Expiration Date: _____

INPUT (X) NO (PPB)	RESPONSE (Y)			NO % DIFF	NO BEST-FIT DETERMINATION		
	NO (PPB)	NO ₂ (PPB)	NO _x (PPB)		Predicted (Y)	Residual (PPB)	Residual (<2% Full Scale)
				/			

Calibration Regression Analysis:
 Corr. Analyzer Response (Y) = m(calib input(X)) + b

Criteria: All points within ±2% of calibration range of best-fit straight line

NO _x % DIFF	NO _x BEST-FIT DETERMINATION		
	Predicted (Y)	Residual (PPB)	Residual (<2% Full Scale)
/			

	NO	NO_x		NO	NO_x
Slope (m)			1.05 to 0.95		
Intercept (b)			(≤ ± 10)		
Correlation Coefficient (r)			(≥ 0.995)		
Average % Difference					

Calibrated By _____ = cell containing equations



NITROGEN DIOXIDE CALIBRATION SHEET ASFOUNO

SITE NAME Date start time
PROJECT Stop time
SITE OPERATOR

Analyzer M Anal. Range 0- ____ -20_0_ PB
 Analyzer Model
 Analyzer s/n

CALIBRATION EQUIPMENT:

Calibrator: 0 Auclit Gas: Zero Air Source:
 Model: 0 Concentration: Model:
 Serial #: 0 Serial #: Serial #:
 Cert Date: Certificate Expiration Date:
 Expiration Date:

CAL INPUT {X}	CAL. IC ACTUAL {Y}	DAS.RESPONSE {Y}			CALIBRATION {Y}					% DIFF NO ₂ {% OR PPB}
		NO _x {PPB}	NO ₂ {PPB}	NO ₂ {PPB}	[ORIG]		[REM]		[CONV]	
					NO _x {PPB}	NO ₂ {PPB}	NO _x {PPB}	NO ₂ {PPB}	NO ₂ {PPB}	
	0.0				-	-	-	-		

NO₂ CALIBRATION

0.0

$[NO_2]_{act} = [NO_2]_{meas} - [NO_2]_{bias}$
 $[NO_2]_{act} = [NO_2]_{meas} - [NO_2]_{bias}$

Slope (m) x-axis: [NO₂]
 y-axis: [NO₂]

Converter Efficiency (%),
 $Efficiency = \frac{m \times 100}{100} = \dots$ (96% - 104%)

NO ₂ BEST-FIT DETERMINATION		
predicted (Y)	Residual (Y)	Residual (Y)
	(Y)	(Y)

Criteria: All points within ±2% of calibration range of best-fit straight line

Calibration Regression Analysis: Co.r.r. Analyzer Response (Y) = m(cal input(X)) + b

Slope (m) 1.05 to 0.95
 Intercept (b) (±10)
 Correlation Coefficient (R) (? : 0.995)
 Average % Difference

Calibrated By cell containing equations



NO_x ANALYZER VERIFICATION & CALIBRATION

ABBR.			
CLIENT		FIELD SPECIALIST	DATE
SITE NAME			DATE OF LAST VISIT

AS FOUND

	AMBIENT ANALYZER	GAS DILUTION SYSTEM
Manufacturer	-	
Model		
Serial Number		
		CALIBRATION GAS
		Cylinder S/N
		Expiration Date
		Cylinder Pressure
		Delivery Pressure
		Tank Conc. NO (ppm)
		Tank Conc. NO _x (ppm)

CALIBRATION ACCEPTANCE CRITERIA (<=)	
Mean Absolute Difference (%)	5%
Maximum Absolute Difference (%)	5%

DATA ACCEPTANCE CRITERIA (<=)	
Mean Absolute Difference (%)	15%
Maximum Absolute Difference (%)	15%
Converter Efficiency	98%

Trace Level Calibrator? No
 FULL SCALE (ppb) 500

NO DILUTION	GAS DILUTION	NO			NO ₂		NO _x				
		Point	Target	Z-air Flow	Gas Flow	Actual	DAS	%Diff	Actual	DAS	%Diff
ZERO	0										
SPAN	400										

Point	GPT	NO	O ₂	GAS DILUTION SYSTEM			NO			NO ₂			NO _x				
				Z-air Flow	O ₂ Flow	Gas Flow	Actual	DAS	%Diff	Actual	DAS	%Diff	LINEAR%	Actual	DAS	%Diff	
ZERO	0	0															
GPTZ	400	200															
GPT	400	200															
GPTZ	300	150															
GPT	300	150															
GPTZ	200	100															
GPT	200	100															
GPTZ	100	50															
GPT	100	50															
GPTZ	70	35															
ZERO	0	0															

Per 40 CFR Part 50 App F 1.5.9 & 1.5.10
 [NO₂]_{amb} [NO₂]_{int} [NO₂]_{org} [NO]_{amb} [NO_x]_{org} [NO_x]_{amb}

	NO	NO ₂	NO _x
Mean ABS % Diff			
Max ABS % Diff			

Slope			
Y-Intercept			
Correlation			

Converter Efficiency		
----------------------	--	--

You must run all points!

Analog Test	NO DAS Conc.	NO ₂ DAS Conc.	NO _x DAS Conc.
Zero			
Full Scale			

NOTES:

Appendix A.2 Standard Operating Procedure for Performance Evaluations of Gaseous Analyzers

Wyoming
Department of Environmental
Quality – Air Quality Division



WYOMING DEPARTMENT OF
ENVIRONMENTAL
QUALITY

Standard Operating Procedure
For Performance Evaluations of Gaseous Analyzers

Date December 2024

Revision 3

1.0 Scope and Applicability

This SOP applies to the quality assurance activities involving the performance evaluations of gaseous analyzers within the WDEQ-AQD air quality monitoring network. Performance evaluations are required by 40 CFR Part 58 Appendix A for comparison to the NAAQS. They must be completed annually at a minimum. This SOP details the procedures WDEQ-AQD will take to prepare and perform the performance evaluations in the field. Occasionally, the WDEQ-AQD may contract out the performance evaluations. If this is the case, the Contractor may have their own SOP to follow. This SOP does not pertain to the National Performance Audit Program (NPAP) or Through the Probe (TTP) audits.

1.1 Introduction

Performance evaluations are performed with independent equipment and personnel from data generation. For WDEQ-AQD, the QA Coordinator or designated Contractor will travel to the site location with independent equipment to perform the audit. The audit is performed by using a certified gas cylinder independent from the site, an independent source of zero air, and an independent gas calibration system with a certified ozone photometer.

It is a requirement for comparison to the NAAQS, that the criteria pollutant analyzers are audited annually at a minimum and quarterly at NCore locations.

2.0 Summary of Method

This method is for use for auditing WDEQ-AQD gaseous analyzers. The parameters to be audited include ozone, sulfur dioxide, carbon monoxide, nitrogen dioxide, and hydrocarbons. Audits will be performed quarterly or semi-annually depending on the station.

2.1 Definitions

The following terms that are used throughout this document are defined here:

- **NIST:** This acronym refers to the National Institute of Standards and Technology. This is a laboratory in Washington D.C. that creates standards for instruments and materials for government and non-governmental entities and also cooperates with other countries to create international standards. This is performed so that a value of one thing in data collected anywhere in the world or U.S. is comparable to the same information collected somewhere else.
- **NIST Traceability:** This term refers to a “transfer” of a standard or technique that allows the known standardization of one material or instrument to another. For example with sulfur dioxide, this is done by using sulfur dioxide gas that has been tested by a NIST traceable instrument and then placed into a compressed gas aluminum cylinder. In addition, the flow rates of the mass flow calibration (MFC) unit is also calibrated using NIST traceable flow devices, so that the operator in the field will know the level of gas that is being delivered within a known level of confidence. All gaseous analyzers within the WDEQ-AQD network are NIST traceable.
- **Mass Flow Controlled Calibration Unit:** The MFC is an instrument that can precisely

control the flow of gases with its mixing chamber. Most MFC can have several high pressure gas cylinders attached to it and be able to blend those gases with purified air in ratios as low as 1000 to 1. In this way, only small amounts of sulfur dioxide are used and blended with large quantities of zero air to get concentrations in the ranges of the instruments. This is a very cost effective way to calibrate the instruments over a long period of time.

3.0 Health and Safety Warnings

The following health and safety warning must be followed in order for safe operation of the instrument.

- Analyzers generally operate using 110 VAC current. Therefore, if troubleshooting, be extremely cautious against electric shock. This can both harm a person and possibly harm the instrument.
- SO₂ and O₃ analyzers use a pulsed Ultraviolet (UV) lamp within the optics portion of the instrument. Do not look directly at the lamp if it is lit. The UV can burn your retinas and cause blindness.
- When generating any gas, be sure to ventilate the area thoroughly. NIST traceable gas cylinders are often blended with gases, such as sulfur dioxide (SO₂), carbon monoxide (CO), nitric oxide (NO), nitric oxides (NO_x), methane (CH₄), and/or Propane (C₃H₈). If possible, vent all excess calibration gas outside and avoid breathing it if possible. SO₂, CO and NO can be hazardous and damage lung tissues.
- Always use a third ground wire on all instruments.
- Always unplug the analyzer when servicing or replacing parts
- If it is mandatory to work inside an analyzer while it is in operation, use extreme caution to avoid contact with high voltages inside the analyzer. The analyzer has high voltages in certain parts of the circuitry, including a 110 volt AC power supply that drives the UV lamp voltage. Refer to the manufacturer's instruction manual and know the precise locations of these components before working on the instrument.
- Avoid electrical contact with jewelry. Remove rings, watches, bracelets, and necklaces to prevent electrical burns.

4.0 Cautions

- The photomultiplier tube (PMT) within the instrument is very fragile. Use extreme caution when handling the PMT.
- Keep the interior of the audit equipment clean.
- Inspect the tubing within the instruments regularly for structural integrity.
- To prevent major problems with leaks, make sure that all sampling lines are reconnected after required checks and before leaving the site.

4.1 Interferences

The audit criteria for each point takes into account the use of independent equipment and any possible interferences.

5.0 Personal Qualifications

It is the responsibility of WDEQ-AQD or the Contractor to train their auditing staff on instrument operation and maintenance. It is a requirement of the WDEQ-AQD to train their staff and keep records of all training that is performed. Although the analyzers are self-contained, computer operated instrument, there is a level of knowledge of electronics and know-how involved in the operation and maintenance of the instrument. The instrument manual is the best training tool for this.

6.0 Equipment

The following supplies are required for the operation of this instrument:

- **Level 2 Ozone Photometer (Teledyne 400E Ozone Analyzer):** This unit is certified by the EPA annually and is used to certify the level 3 ozone photometer for field audits.
- **Dilution Calibrator/Level 3 Ozone Photometer (Teledyne 700EU Dynamic Dilution Calibrator):** These units use MFCs to blend and dilute gases precisely and allow the user to challenge the analyzers with gas concentrations of known quantity and accuracy. The unit also has the capability of generating known concentrations of ozone and allows the user to challenge the ozone analyzer and NO₂ analyzer.
- **NIST traceable gas cylinder:** Numerous vendors can provide stable, NIST traceable blended gas (SO₂, CO, NO, NO_x, CH₄ and/or C₃H₈) cylinders with concentrations that are periodically verified by the vendor.
- **Zero Air Generator (Teledyne 701 Zero Gas Generator):** Zero air is required for the calibration of sulfur dioxide instruments. This air must be free of ozone, NO, NO₂, and SO₂ to 0.001 ppm and CO and non-methane hydrocarbons to 0.1 ppm or below the instruments detection limit (whichever is lower). They must also be free of water vapor and particulates.
- **BIOS Defender Flow Meter:** NIST traceable standards used to calibrate the MFCs located in the calibrator.
- **Tubing and Fittings:** Teflon is an inert material that is used exclusively throughout the system. All fittings and ferrules must also be made of PFA or PTFE Teflon.

6.1 Inspection/Acceptance of Supplies and Consumables

Spare parts will be purchased only from the instrumentation manufacturer by the QA Coordinator. Parts will be inspected by the QA Coordinator for shipping damage upon receipt. Spare parts will be kept in the WDEQ-AQD workshop for use when needed.

The gaseous analyzers, the multi-gas calibrator, gas cylinders and zero-air system use inlet filters, Purafil, charcoal. These supplies do not require acceptance testing. The Purafil and charcoal are replaced yearly or more frequently, as needed.

7.0 Quality Assurance Procedures

Performance evaluations are required to be performed at a minimum of annually for SLAMS/SPMS and quarterly for NCore sites. The WDEQ-AQD will perform performance evaluations within the network semi-annually for SLAMS/SPMS locations and quarterly for the Cheyenne NCore and Boulder locations.

The performance evaluations are made by challenging the gaseous analyzers with audit gas standards of known concentrations from a minimum of three audit levels. The audit levels are listed in **Table 1**. The audit points chosen should reflect the following as stated in 40 CFR Part 58 Appendix A 3.1.2.1:

1. One point must be within 2-3 times of the method detection limit of the instruments within the PQAO network (Note: This will be limited by the starting gas concentration and the limitations of the MFCs within the calibrator).
2. The second point will be less than or equal to the 99th percentile of the data at the site or network of sites in the PQAO or the next highest audit concentration level.
3. The third point can be around the primary NAAQS or the highest 3-year concentration at the site or network of sites in the PQAO.

Passing criteria for audits are based on the gas and audit level.

- O₃, SO₂, NO₂: Audit levels 3-10 → 15.1%; Audit levels 1-2 → 1.5 ppb or 15.1%, whichever is greater
- CO: Audit levels 3-10 → 15.1%; Audit levels 1-2 → 0.031 ppm or 15.1%, whichever is greater
- NO, NO_x, NO_y, NO_y-NO, CH₄, NMHC, THC: No audit criteria, however a good target is within 15.1%.

Table 1. Audit levels listed in 40 CFR Part 58 Appendix A

Audit Level	Concentration Range (ppm)			
	O ₃	NO ₂	SO ₂	CO
1	0.004 - 0.0059	0.0003 - 0.0029	0.0003 - 0.0029	0.020 - 0.059
2	0.006 - 0.019	0.0030 - 0.0049	0.0030 - 0.0049	0.060 - 0.199
3	0.020 - 0.039	0.0050 - 0.0079	0.0050 - 0.0079	0.200 - 0.899
4	0.040 - 0.069	0.0080 - 0.0199	0.0080 - 0.0199	0.900 - 2.999
5	0.070 - 0.089	0.0200 - 0.0499	0.0200 - 0.0499	3.000 - 7.999
6	0.090 - 0.119	0.0500 - 0.0999	0.0500 - 0.0999	8.000 - 15.999
7	0.120 - 0.139	0.1000 - 0.2999	0.1000 - 0.1499	16.000 - 30.999
8	0.140 - 0.169	0.3000 - 0.4999	0.1500 - 0.2599	31.000 - 39.999
9	0.170 - 0.189	0.5000 - 0.7999	0.2600 - 0.7999	40.000 - 49.999
10	0.190 - 0.259	0.8000 - 1.000	0.8000 - 1.000	50.000 - 60.000

7.1 Instrument Setup and Calibrations prior to Performance Evaluations

The dilution calibrator, which is used in field audits, contains mass flow controllers, an ozone photometer and an ozone generator. It is critical for the performance evaluations that work be done to calibrator and verify the dilution calibrator prior to entering the field.

7.1.1 Equipment Setup in WDEQ-AQD Workshop

WDEQ-AQD has a workshop space to perform the activities needed in preparation for field audits. At this site, the zero air generator, level 2 ozone photometer and dilution calibrator are set up on a stand. Using the following set up to ensure equipment is connected properly.

1. Place all instruments on rack in workshop
2. Connect dilution calibrator to the level 2 ozone photometer using one of the ports labeled CAL OUT on the dilution calibrator and the SAMPLE port on the level 2 ozone photometer. See **Figure 1** and **Figure 2**.
3. Connect the zero air generator to the dilution calibrator and level 2 ozone photometer using a T.
 - a. The port on the dilution calibrator is labeled DILUENT IN. See **Figure 2**.
 - b. The port on the level 2 ozone photometer is labeled ZERO AIR DRY AIR.
 - i. Using a T with a vent, connect a rotometer to make sure excess air is supplied to the analyzer. This can be adjusted once analyzer is properly warmed up.
 - c. Finger tighten the fitting and then use a properly sized wrench to make an additional 1 and ¼ turn.
4. Attach a line to vent the dilution calibrator with the minimum O.D. being 3/8 inch.
5. Plug in all three instruments and turn on the Dilution Calibrator and Zero Air Generator. Let them warm up for a minimum of 1 hour.
 - a. DO NOT turn on the Level 2 Ozone Photometer until the Dilution Calibrator is generating ozone or 0.0 ppb ozone.

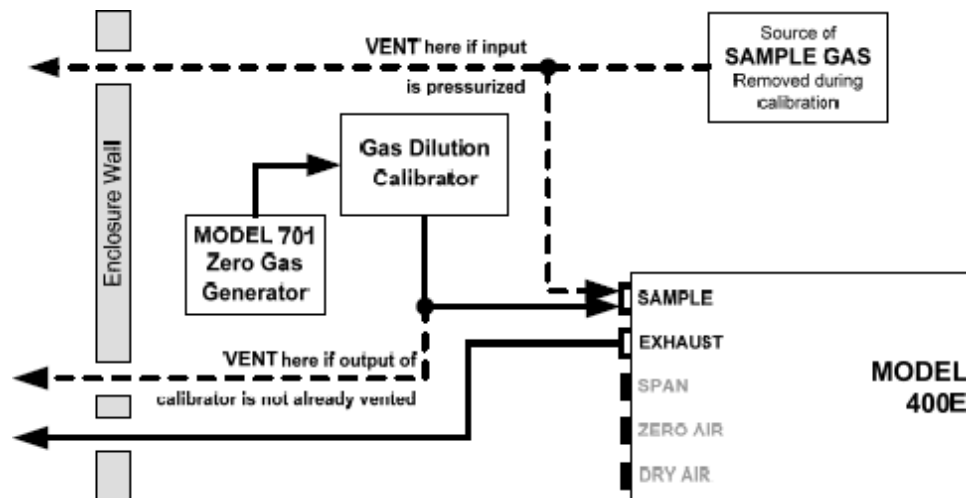

Figure 1. Connections with level 2 ozone photometer

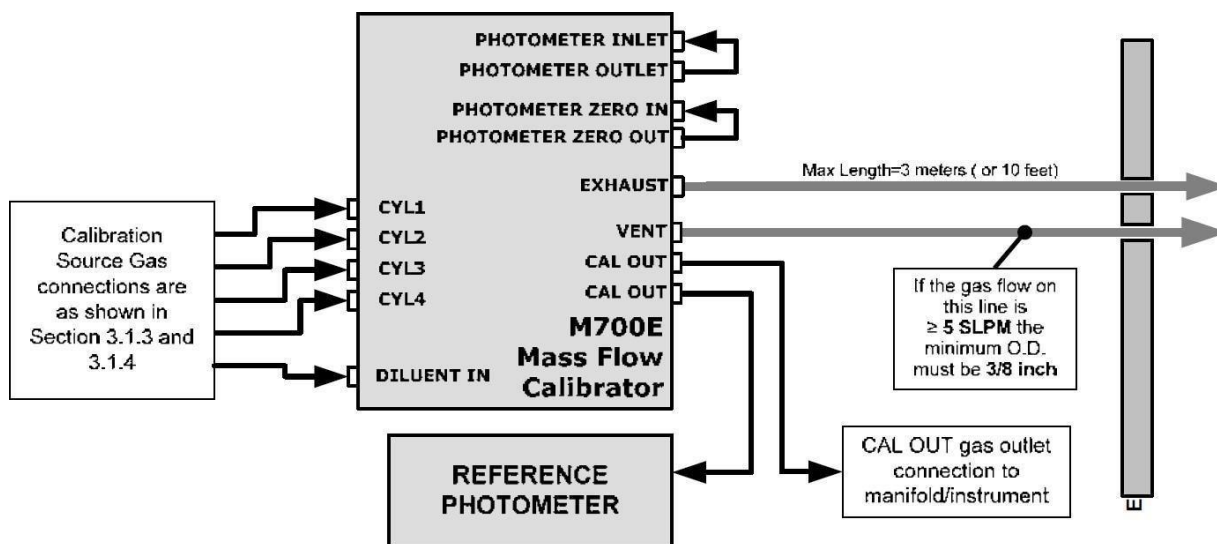

Figure 2. Connections with dilution calibrator

7.1.2 Calibrating MFCs in Calibrator

According to the instrument manual for the dilution calibrator, the MFCs should be verified periodically and calibrated if necessary. By verifying, and adjusting when necessary, the MFCs, the auditor can be confident that the concentrations of gas delivered to the analyzer are accurate. The MFCs should be verified at a minimum of every 6 months, but ideally quarterly.

1. The BIOS flow meters are required for this procedure.
 - a. To setup the BIOS after recertification
 - i. Setup → Reading → Type:STD → Exit
 - ii. Units → SL/min flow in and Std T: 25C → Confirm to save
 - iii. Preferences → Read default Burst => 10 readings average
2. Open the front panel to the dilution calibrator to access the MFC output ports
3. Attach the proper BIOS flow meter directly to the output port of the MFC to be checked. **See Figure 3.**
 - a. Note that the Diluent MFC will use the BIOS 220H model and the Cal Gas MFCs will use the BIOS 220L model.

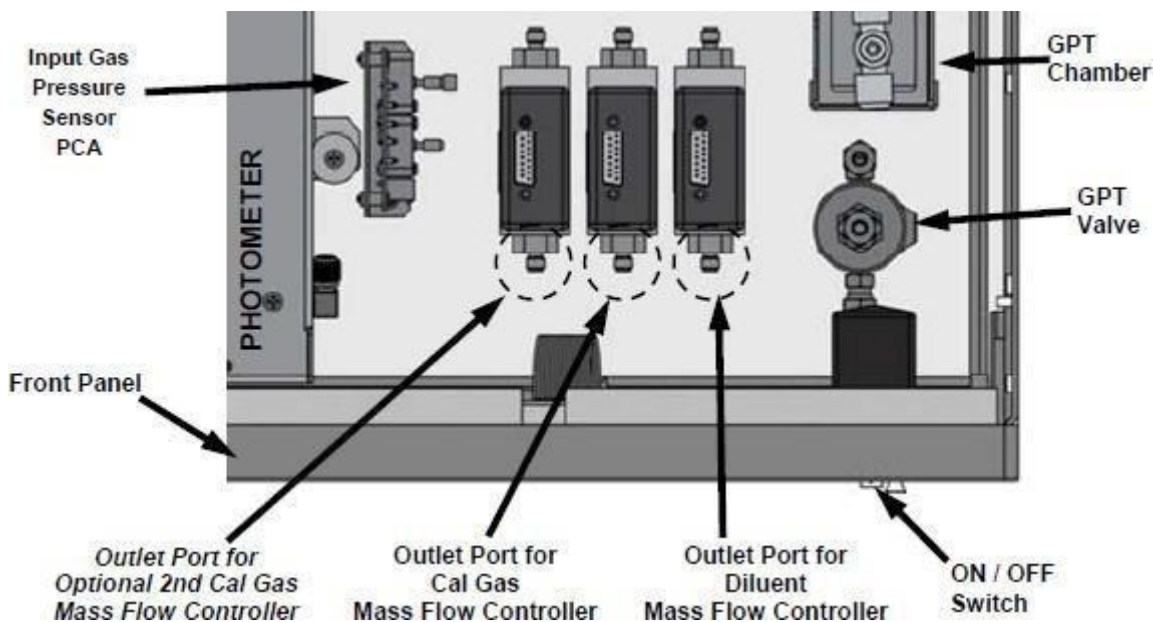

Figure 3. Diagram of mass flow controllers within a dilution calibrator

4. Turn on the BIOS flow meter
5. Perform the following steps to verify and/or calibrate the MFCS
 - a. Make sure Calibrator is in standby mode. If it is not, put into standby with **STBY** key.
 - b. → **SETUP** to access the **PRIMARY SETUP MENU**
 - c. → **MORE** to access the **SECONDARY SETUP MENU**
 - d. → **DIAG** → **ENTER PASSWORD 929** → **ENTR** will bring up **SIGNAL I/O** submenu
 - e. → **NEXT** (continue pressing **NEXT**) to access the **MFC CONFIGURATION** submenu
 - f. → **ENTR** This will bring up the first MFC, **DIL1** (other options are **CAL1** or **CAL2**). Select the MFC desired by using the **<SET SET>** keys.
 - g. → **EDIT** → **SET** → **>** until **DIL1 Table** is shown This will bring up the table for the MFC selected
 - i. If the MFC is **OFF**, press **OFF** to turn the key to **ON**
 - h. Enter the **DRV** and **FLW** for the calibration point on the MFC Verification and Calibration Form.
 - i. On BIOS: press Start to begin the Burst readings and wait until the readings are completed. Record the flow on the MFC Verification and Calibration Form.
 - i. When doing **CAL2** this may take a while, it is not necessary to wait for all 10 reading for the really low flow points if the readings are very close together.
 - j. If the average flow from the BIOS is within 2% of the value on the calibrator, no adjustment is needed. If the average flow from the BIOS differs by more than 2% use the following steps to make the adjustment.
 - i. → **Flow** → Toggle keys to match the average flow from the BIOS → **ENTR** to

save

- k. →NEXT will move to next calibration point
- l. Repeat steps h-k for all 20 points for the MFC
- m. Once all points have been verified and necessary adjustments made
→EXIT→SAVE CHANGES?→YES
- n. Disconnect BIOS flow meter from MFC and proceed to connect to next MFC.
 - i. Note that the Diluent MFC will use the BIOS 220H model and the Cal Gas MFCs will use the BIOS 220L model.
- o. Repeat steps f-n for the other MFCs
 - i. Note gas source must be connected to CYL1 port for gas MFCs to work.

7.1.3 Verification and Reverification of the Level 3 Ozone Field Transfer Standard

The Ozone Level 3 Field Transfer Standard is required to be verified at a minimum of every 6 months. Due to the drift that can occur in the transport to and from the field, verifications can be performed more often or done quarterly. The verification and reverifications must be made against an Ozone Level 2 Bench Transfer Standard (which must have a current verification to an Ozone Level 1 Standard Reference Photometer (SRP)). The verification and reverifications will result in a linear regression relationship of the Level 3 Transfer Standard to the Level 2 Transfer Standard. This procedure is based off of the Ozone TAD document.

1. Follow section 7.1.1 of this SOP to set up equipment.
2. While equipment is warming up, review all preventive maintenance documentation for the Level 3 Field Transfer Standard/Dilution Calibrator.
3. After performing preventive maintenance to the Level 3 Field Transfer Standard/Dilution Calibrator, start generating 0.0 ppb ozone. Once generating ozone, turn on the Level 2 Transfer Standard and let warm up for ~1 hour.
 - a. On the Dilution Calibrator
 - i. →GEN→AUTO→press gas key until O3
 1. Enter 0.0 ppb O3
 2. Enter Flow Rate (ie. 7.000 LPM, use the same flow rate every verification/reverification)
4. If performing a reverification, review the previous verification data, verification history, as-left internal calibration factors from the verification, and the current internal calibration factors.
 - a. If the internal calibration factors have changed, determine why they have changed and if the transfer standard has been used subsequently. Changing the internal calibration factors in a transfer standard voids the previous verification.
5. Once the equipment (Level 3 Transfer Standard/Dilution Calibrator) is warmed up, perform acceptance testing and fill out the Acceptance Testing Form.
 - a. Acceptance testing is required upon receiving a transfer standard and prior to verifications and reverifications.
 - b. This is done to ensure the transfer standard is operating within the manufacturer's specifications.
 - c. Acceptance testing should include:
 - i. Documentation of testing date, time, operator, instrument

- make/model/serial number (SN);
 - ii. Documentation ensuring routine maintenance required by the instrument manual has been performed;
 - iii. Direct comparison of sensors impacting the measurement (i.e., sample pressure, sample temperature, analog outputs) if recommended by the instrument manual or if sensor adjustment is required;
 - iv. Documentation of diagnostic parameters in the instruments' menu system and comparison to the manufacturer's specifications (i.e., sample pressure, sample temperature, flow);
 - v. Review and verify that all acceptance test data are within acceptable limits.
6. Begin by filling out the Ozone Verification/Reverification Form. This form is from the EPA and will be utilized for the verification and reverification process.
7. Determine the calibration scale and verification points:
- a. Take the previous 3 years of 1-hour values for all WDEQ-AQD sites. Determine the highest value.
 - i. EXAMPLE: For the year 2021, the highest value was 0.129 ppm and occurred at the Boulder Station in 2019.
 - b. Multiple the highest value by 1.5 to establish the calibration scale. If the highest point is below the NAAQS, use 1.5 times the controlling NAAQS.
 - i. The highest point used for the Level 3 Transfer Standard must be less than the highest point used in the Verification/Reverification of the Level 2 Transfer Standard.
 - ii. EXAMPLE: Taking the number above (0.129 ppm) * 1.5 = 0.1935 ppm. To simplify calculations, the high end point will be 0.200 ppm.
 - c. Five additional points will be evenly spaced out between the calibration scale point and zero, for a total of 6 verification points and a zero.
 - i. EXAMPLE: An acceptable 6 verification points using the above calculation could be 0.200, 0.160, 0.120, 0.090, 0.060, 0.030, 0.000 ppm
8. For a Verification: Run at least 3 complete cycles consisting of a minimum of 6 concentration points and a zero. See above Step 6 for determining the concentration points. See Step 10 for how to run points on the transfer standard.
9. For a Reverification: Run one cycle consisting of a minimum of 6 concentration points and a zero. See above step 6 for determining the concentration points. See Step 10 for how to run points on the transfer standard.
10. Steps to run a concentration point on the Level 3 Transfer Standard:
- a. Make sure that the dilution calibrator is in **STANDBY** mode or press **STBY**
 - b. **→GEN→AUTO→ZERO** toggle this key to scroll through the available gas types (as programmed during initial set up, See Section 7.2.1 if no gas types are programmed) and continue until **03** is selected.
 - c. Toggle keys to set target concentration and unit. See steps for determining the concentrations to run.
 - d. **→ENTR→Set TOTAL FLOW**
 - i. 7.0 LPM is a good starting point for the flow rate. If an MFC warning appears, the flow rate should be adjusted.

- e. →<SET press this key until the **ACT** test function is displayed
 - f. Wait a minimum of 10 minutes or until the **ACT** reading settles down
 - g. Record the readings for the O₃ concentration readings displayed by the **ACT** test function and the level 2 ozone transfer standard.
 - i. 10 points can be recorded and averaged for each concentration point, but this has to be done outside of the Ozone Verification/Reverification Form from the EPA.
 - h. Repeat this procedure for the concentration points determined in Step 6 and the number of cycles necessary for a verification or reverification.
 - i. The Ozone Verification/Reverification Form will perform all the necessary calculations.
11. After cycle/cycles are completed, review the data and verify that the meet the following acceptance criteria:
- a. Each point difference must be $<\pm 3.1\%$ or 1.5 ppb for concentrations below 50 ppb.
 - b. All Regression Slopes must be 1.00 ± 0.03
 - c. All Regression Intercepts must be 0 ± 3 ppb
 - d. Standard Deviation of the 3 Slopes must be $<\pm 0.0075$
 - e. Standard Deviation of the Intercepts must be $<\pm 1.00$ ppb
 - f. For a Verification: The three cycles regression slopes and intercepts are used to generate the 95% predication interval specific to that standard. The standard specific prediction intervals are used when assessing the results of a reverification.
 - g. For a Reverification: The regression slope and intercept must fall within the transfer standards specific 95% prediction interval determined by the most recent 3 cycles (not updated with current cycle until acceptance criteria is met).
 - i. If the results pass all criteria and are within the 95% predication interval, then the transfer standard passes the reverification.
 1. A new prediction interval is calculated using the most recent 3 cycles. The updated prediction intervals are used as the prediction interval acceptance criteria when assessing the results of the next reverification.
 - ii. If the results are outside of the 95% prediction interval, then the transfer standard must be assessed to determine what caused a shift in the results and a new verification must be performed if the investigation requires repair or adjustment of internal calibration factors.
12. Ensure that all documentation is complete and all records are saved to the appropriate location. Place a summary report on the verified transfer standard which includes:
- a. Date of verification
 - b. Date of verification expiration
 - c. Name of person conducting the verification
 - d. Make/model/SN
 - e. Current internal calibration factors
 - f. Dates/slopes/intercepts of the original verification cycles
 - g. Average slope and intercept

13. The linear regression slope and intercept will be used to correct ozone concentrations when performing a performance evaluation.

7.2 Field Audits

Field audits are performed by bringing an independent zero air source/generator, dilution calibrator, and gas cylinder to the field site. Three audit points and a zero point must be run for each analyzer. This information confirms that the site equipment is operating properly. If an analyzer fails the audit, a corrective action must be issued and resolved and the analyzer must be audited after.

7.2.1 Equipment Setup

Prior to running any audit points, all of the equipment must be set up, turned on and warmed up.

1. Connect the audit zero air generator to the audit dilution calibrator using the port labeled DILUENT IN. See **Figure 2**.
 - a. Finger tighten the fitting and then use a properly sized wrench to make an additional 1 and ¼ turn.
2. Plug both the audit zero air generator and audit dilution calibrator into a power source. Turn both on and let warm up for approximately 1 hour (or until the box temperature of the dilution calibrator is above 20 °C at a minimum).
3. Set up and purge gas cylinder
 - a. The gas regulator may be already installed on the cylinder and a DOT cylinder cap can be used for transport of the cylinder with the regulator installed. If not installed, install the regulator on the gas cylinder.
 - b. Attach a stainless steel line to the gas regulator.
 - c. Purge the gas cylinder approximately 10 times. This is really important for gas cylinders with NO in them.
 - i. Make sure the outlet valve on the regulator is closed
 - ii. Open the tank valve to pressurize
 - iii. Close the tank valve
 - iv. Slowly open the outlet valve on the regulator and watch the pressure gauges drop to zero. Right before the second pressure gauge hits zero, close the outlet valve.
 - v. Repeat 7-10 times
 - d. Attach gas cylinder to audit dilution calibrator using the port labeled CYL1. See **Figure 2**. Allow gas to slowly run through stainless steel line while attaching. Once attached, open valve on regulator to let ~30 psi of gas to the calibrator
 - e. Program in the gas cylinder for the audit dilution calibrator. Note, if this step is previously done, you don't need to repeat it. The instrument will store the gas cylinder information.
 - i. **→SETUP→GAS→CYL→PRT1**
 1. Use **NEXT** or **ADD GAS** keys
 2. Enter in cylinder contents
 - ii. This will allow for the dilution calibrator to make the correct dilutions of cylinder gas and zero air.
4. Once equipment is set up and warmed up, use the data logger to flag the required channels
 - a. Most of the time the O₃/SO₂/CO/NO/NO_x/NO₂/CH₄/NMHC/THC sample lines T together to have one tube for the inlet to the site dilution calibrator. These

- channels all have to be flagged at the same time for the audit. This goes for any site where sample lines T together.
- b. The NO/NO_y analyzer will be separate and will be flagged only when auditing.
5. Detach the CAL OUT or OUTPUT A line from the site dilution calibrator and attach it to the audit calibrator. Now the flow of audit gas goes from the gas cylinder through the audit dilution calibrator to the site analyzers and is then vented out the site analyzer.
 - a. There are other possible ways to connect to the site analyzers, just ensure that there is a vent on the system or the audit system. There should only be one vent, but there has to be a vent.
 6. Determine the total flow required by the system.
 - a. Add the gas flow requirements for each of the analyzers in the system.
 - i. This can be found using the <TST TST> keys on the front of the Teledyne analyzers and scrolling.
 - ii. Take into account the 800 cc/min for the ozone photometer for the audit dilution calibrator
 - b. Multiply by 1.5
 - c. Using this calculation will ensure that more than enough gas is being supplied to each analyzer.
 - d. For all WDEQ-AQD sites, 7.0-7.5 LPM should be sufficient.
 7. Check the diluent pressure on the audit dilution calibrator by using the <TST TST> keys to scroll until DIL PRESSURE appears. This pressure should be around 30 psi or the zero air will need to be adjusted. Start low on the pressure and slowly increase, if the pressure goes over 30 psi, you may have to bleed off the excess.
 8. Check the cal gas pressure on the audit dilution calibrator by using the <TST TST> keys to scroll until CAL PRESSURE appears. This pressure should be around 30 psi or the gas cylinder regulator will need to be adjusted. Start low on the pressure and slowly increase, if the pressure goes over 30 psi, you may have to bleed off the excess.

7.2.2 SO₂, CO, NO_x, Total Hydrocarbons (THC) Analyzers Audit

The SO₂, CO, NO/NO_x and THC analyzers should be all in line together and connected to the site dilution calibrator with one line. If they are not in this configuration, then they will have to be audited separately.

1. Using **Table 1** and historic data, determine the audit points desired for each analyzer. All analyzers can be audited simultaneously with proper planning and the proper mixed gas cylinder.
2. Zero air audit point: This can be performed for O₃ as well if following these steps
 - a. **→GEN→AUTO→Press gas key until ZERO**
 - b. **→ENTER→FLOW RATE**
 - i. See above 7.2.1 step 6 for determining the proper flow rate for the system
 - c. **→ENTER**
 - i. The system should now be generating zero air
 - d. Let point stabilize for 10-15 minutes or until readings are stable.
 - e. Record zero air point on all audit forms.
3. Start with the span/high point for NO_x. This will not be used for the NO₂ audit, but is helpful to know if there are any issues prior to the audit and also allows for higher points of other gases to be generated for the other analyzers' audits (Only one gas has

- to be set, the analyzer will dilute based on the gas set and the other gas points can be calculated based on the dilution).
- a. EXAMPLE: if the range of the NO_x analyzer is 200.0 ppb.
 - i. Set NO to 200.0 ppb
 - ii. This point can be discretionary based on the points needed for the other analyzers to be audited.
 - b. Enter the desired gas amount following these steps:
 - i. **→GEN→AUTO→press gas key until NO (or desired gas)**
 1. Enter concentration for gas selected
 - ii. **→ENTER→FLOW RATE**
 1. See above 7.2.1 step 6 for determining the proper flow rate for the system
 - iii. **→ENTER**
 - c. Record the DIL, GAS and DAS values for all gases.
 - i. The DIL and GAS values will be used to calculate the actual amount for each gas that was generated, based off of the starting concentration of the gas cylinder.
 - ii. The DAS values will be compared to the actual amount for each gas.
4. Repeat step 2 above after running the NO_x span/high point.
 5. Perform at least 3 non-zero audit points and try to hit the requirements for each analyzer. This may require more than 3 audit points.
 - a. One point must be within 2-3 times of the method detection limit of the instruments within the PQAQ network (Note: This will be limited by the starting gas concentration and the limitations of the MFCs within the calibrator).
 - b. The second point will be less than or equal to the 99th percentile of the data at the site or network of sites in the PQAQ or the next highest audit concentration level.
 - c. The third point can be around the primary NAAQS or the highest 3-year concentration at the site or network of sites in the PQAQ.
 6. To perform the NO₂ audit, GTPZ and GPT points will be run. Additional gases can be audited simultaneously to the GPTZ points.
 - a. Run the first GPTZ (Gas Phase Titration Zero) point
 - i. **→GEN→AUTO→GPTZ**
 1. Enter the desired NO concentration (ie. 120 ppb)
 2. Enter the desired O₃ concentration (ie. 60 ppb)
 3. Enter the desired flow rate (ie. 7.000 LPM)
 - ii. This will generate a GPTZ point, which runs like a GPT point without generating ozone.
 - iii. Wait for all gases to stabilize (~10-15 minutes) and record the DIL, GAS, O₃FLOW, and DAS values for all gases you wish to audit (ie. You can record SO₂, CO, CH₄, NMHC and THC values at this point). At a minimum you will need to record the NO, NO₂, and NO_x values.
 - b. Run the first GPT (Gas Phase Titration) point
 - i. **→GEN→AUTO→GPT**
 1. These values will be the same as the GPTZ point previously run

2. Enter the desired NO concentration (ie. 120 ppb)
3. Enter the desired O₃ concentration (ie. 60 ppb)
4. Enter the desired flow rate (ie. 7.000 LPM)
- ii. Wait for all gases to stabilize (~10-15 minutes) and record the DIL, GAS, O₃FLOW, O₃DRIVE and DAS values for NO, NO₂, and NO_x.
- iii. The audit spreadsheet will perform all calculations.
- c. Repeat the above steps a and b for additional NO, NO₂ and NO_x points (ie. 50 ppb NO/20 ppb O₃ and 10 ppb NO/3 ppb O₃).
7. If other gas analyzers need additional points, follow step 3 above.

7.2.3 O₃ Analyzer Audit

The Ozone analyzer must be audited separately because O₃ gas is not stable enough to be stored in gas cylinders and must be generated at the time of the audit. The dilution calibrator will generate a known amount of ozone, which is known from the internal photometer and that gas is transferred to the site ozone analyzer. Since no additional gas is needed, the ozone generator and photometer within the dilution calibrator can be run simultaneously.

1. See Section 7.2.2, Step 2 for the zero point.
2. Prior to running O₃ audit points, it is a good idea to run the back pressure compensation.
 - a. **→SETUP→MORE→DIAG→BACK PRESSURE COMPENSATION→ENTER**
3. Begin with an ozone zero point.
 - a. This is done by generating 0.0 ppb ozone.
 - i. **→GEN→AUTO→press gas key until O₃**
 1. Enter 0.0 ppb O₃
 2. Enter Flow Rate (ie. 7.000 LPM)
 - ii. Let the point stabilize for ~10-15 minutes and then record the dilution calibrator value and the DAS value. The calibrator value will be corrected using the slope and intercept from the level 3 transfer standard ozone verification/reverification.
4. Next start with running the highest ozone audit point. This will in a way condition the system and provide the best results for the lower ozone audit points. To determine the audit points, use the following guidance:
 - a. One point must be within 2-3 times of the method detection limit of the instruments within the PQAQ network (Note: This will be limited by the starting gas concentration and the limitations of the MFCs within the calibrator).
 - i. For the Teledyne 400E analyzers, the lower detectable limit is 0.6 ppb. Three times this would be 1.8 ppb. The Teledyne 700EU dilution calibrator has difficulty with accuracy generating ozone below 3 ppb. This point will be set around 15.0 ppb or 0.015 ppm.
 - b. The second point will be less than or equal to the 99th percentile of the data at the site or network of sites in the PQAQ or the next highest audit concentration level.
 - i. Historic data shows ozone values for the 1 hour max and 8 hour max.
 1. EXAMPLE: The greatest 8 hour max from the last 10 years was 0.123 ppm at the Boulder site. The greatest 1 hour max from

- the last 10 years was 0.165 ppm at the Boulder site. The point chosen for this level could be 0.125 ppm.
- ii. If the auditor chooses, this point can vary for sites depending on historical data.
 - c. The third point can be around the primary NAAQS or the highest 3-year concentration at the site or network of sites in the PQAQ.
 - i. This point will be around 0.075 ppm for all sites. The NAAQS is 0.070 ppm, however that is on the edge of an audit level. To ensure the point is always within the same audit level, the point run will be 0.075 ppm.
5. To set the ozone points on the dilution calibrator follow these steps:
- a. **→GEN→AUTO→ZERO→press key until O3**
 - i. Enter concentration for ozone
 - b. **→ENTER→FLOW RATE**
 - i. See above 7.2.1 step 6 for determining the proper flow rate for the system
 - c. **→ENTER**
 - i. The system should now be out of standby mode
 - d. Let point stabilize for ~10-15 minutes and record required information on the Ozone Audit Form.

7.2.4 NO/NO_y Analyzer Audit

The NO/NO_y analyzer uses a different sample line than the NO/NO_x analyzer. Thus the same procedure to audit will need to be performed. The NO/NO_y procedure is the same as section

7.2.2. The NO_x audit form can be modified for NO_y analyzers, the calculation are all the same.

8.0 References

1. Code of Federal Regulations Title 40 Part 58 Appendix A. <https://www.ecfr.gov/current/title-40/part-58/appendix-Appendix A to Part 58>
2. QA Handbook for Air Pollution Measurement Systems: Volume II: Ambient Air Quality Monitoring Program, January 2017. https://www.epa.gov/sites/default/files/2020-10/documents/final_handbook_document_1_17.pdf
3. Teledyne Instruments Technical Manual for Model 700 Dynamic Dilution Calibrator. <https://www.teledyne-api.com/prod/Downloads/083730700D%20-%20MANUAL,%20USER,%20NVS,%20T700,%20T700U.pdf>
4. Teledyne Instruments Manual Addendum for Model 700U Calibrator. <https://www.teledyne-api.com/prod/Downloads/083730700D%20-%20MANUAL,%20USER,%20NVS,%20T700,%20T700U.pdf>
5. Teledyne Instruments Technical Manual for Model 400E Photometric Ozone Analyzer. <https://www.teledyne-api.com/prod/Downloads/T400%20MANUAL,%20USER,%20NVS,%20T400%20083730400B.pdf>
6. Transfer Standards for Calibration of Air Monitoring Analyzers for Ozone, Technical Assistance Document (January 2023). https://www.epa.gov/system/files/documents/2023-11/o3_tad_508_20230906_final.pdf
7. Reference Method for the Determination of Nitrogen Dioxide in the Atmosphere (Chemiluminescence). EPA Quality Assurance Document

2.3 (2002). <https://www3.epa.gov/ttn/amtic/files/ambient/pm25/qa/no2.pdf>

APPENDIX A

MFC Verification and Calibration Form

MFC Calibration																
Date		MFC 1 Air - 228H SN 113688					MFC 2 Gas - 220L SN 112785					MFC 3 Gas - 220L SN 112785				
Drive	Current	Bios	% Difference	Changed Value	Drive	Current	Bios	% Difference	Changed Value	Drive	Current	Bios	% Difference	Changed Value		
250			#DIV/0!		250			#DIV/0!		250			#DIV/0!			
500			#DIV/0!		500			#DIV/0!		500			#DIV/0!			
750			#DIV/0!		750			#DIV/0!		750			#DIV/0!			
1000			#DIV/0!		1000			#DIV/0!		1000			#DIV/0!			
1250			#DIV/0!		1250			#DIV/0!		1250			#DIV/0!			
1500			#DIV/0!		1500			#DIV/0!		1500			#DIV/0!			
1750			#DIV/0!		1750			#DIV/0!		1750			#DIV/0!			
2000			#DIV/0!		2000			#DIV/0!		2000			#DIV/0!			
2250			#DIV/0!		2250			#DIV/0!		2250			#DIV/0!			
2500			#DIV/0!		2500			#DIV/0!		2500			#DIV/0!			
2750			#DIV/0!		2750			#DIV/0!		2750			#DIV/0!			
3000			#DIV/0!		3000			#DIV/0!		3000			#DIV/0!			
3250			#DIV/0!		3250			#DIV/0!		3250			#DIV/0!			
3500			#DIV/0!		3500			#DIV/0!		3500			#DIV/0!			
3750			#DIV/0!		3750			#DIV/0!		3750			#DIV/0!			
4000			#DIV/0!		4000			#DIV/0!		4000			#DIV/0!			
4250			#DIV/0!		4250			#DIV/0!		4250			#DIV/0!			
4500			#DIV/0!		4500			#DIV/0!		4500			#DIV/0!			
4750			#DIV/0!		4750			#DIV/0!		4750			#DIV/0!			
5000			#DIV/0!		5000			#DIV/0!		5000			#DIV/0!			

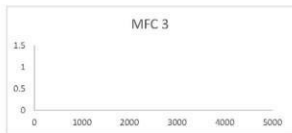
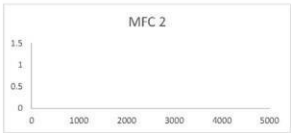
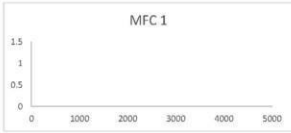

Acceptance Testing Form for Level 3 Transfer Standard

Ozone Transfer Standard Acceptance Testing Form					
Operator					
Organization					
Instrument Make		Teledyne			
Instrument Model		T700			
Instrument SN					
Date Preventive Maintenance Performed					
Transfer Standard Role		Level 3 Field			
Parameters	Prior to Transport	As Found	As Left	Manufacturer Specifications	Displayed As
Date					
Time					
Lab Temperature					
Lab Standard Pressure					
Cal Pressure				25-35 PSIG	CAL PRESSURE
Dilution Pressure				25-35 PSIG	DIL PRESSURE
Regulator Pressure				20 ± 1.0 PSIG	REG PRESSURE
Photo Slope				1 ± 0.03	PHOTO SLOPE
Photo Offset				0 ± 3 ppb	PHOTO OFFSET
Sample Pressure				24-30 In-Hg-A	PHOTO SPRESS
Sample Temperature				28-45 °C	PHOTO STEMP
Photometer Measure				4400-4600 mV	PHOTOMEAS
Photometer Reference				4400-4600 mV	PHOTOREF
Photometer Flow				0.720-0.880 LPM	PHOTO FLOW
Photometer Lamp Temp				58 ± 0.5 °C	PHOTO LAMP TEMP
Dark Offset				0 ± 20 mV	DARK OFFSET
Box Temp				8-48 °C	BOX TEMP
O3 Gen Ref				25-600 mV	O3GENREF
O3 Flow				0.100-0.200 LPM	O3GENFLOW
O3 Gen Drive				800 mV	O3GENDRIVE
O3 Lamp Temp				48 ± 0.5 °C	O3GENTEMP
Comments					
Acceptance Testing is required after a new transfer standard is received from the manufacturer, prior to verification or reverification of a transfer standard, when a transfer standard is shipped, or when a device requires repair. Should follow preventive maintenance.					

Example Ozone Verification Form (see EPA’s Ozone Verification Spreadsheet)

O3 Transfer Standard Verification Data Form

Institute Conducting Verification: WDEQ-AQD Operator: Shabby Wadkins Cycle 3 Date: 9/10/2021 Naming Convention: WDEQ Ozone Verification		Acceptance Criteria Checklist Verification Results: PASS Transfer Standard Role check: PASS Preventive Maintenance Completed: PASS Acceptance Testing Completed: PASS Per Point Difference: PASS Regression Slope Check: PASS Regression Intercept Check: PASS Std Deviation Slope: PASS Std Deviation Intercept: PASS												
Transfer Standard of Higher Authority Transfer Standard Role: Level 2 Bench Make: Teledyne Model: T400 Serial Number: 3121 Verification Date: 4/26/2021														
Calibration Factors Span Setting: 1.006 Zero Setting: 0.5														
Candidate Transfer Standard Information Candidate Transfer Standard Role: Level 3 Field Make: Teledyne Model: T700U Serial Number: 173 Preventive Maintenance Date: 6/13/2021 Acceptance Testing Date: 10/25/2021														
Signature: _____ Date: _____														
Calibration Factors (describe calibration factor changes in comments) <table border="1" style="width: 100%; border-collapse: collapse;"> <thead> <tr> <th></th> <th style="text-align: center;">Span Setting</th> <th style="text-align: center;">Zero Setting</th> </tr> </thead> <tbody> <tr> <td>As Found</td> <td style="text-align: center;">0.995</td> <td style="text-align: center;">0.2</td> </tr> <tr> <td>As Left</td> <td style="text-align: center;">0.995</td> <td style="text-align: center;">0.2</td> </tr> <tr> <td>Comments:</td> <td colspan="2" style="height: 50px;"></td> </tr> </tbody> </table>				Span Setting	Zero Setting	As Found	0.995	0.2	As Left	0.995	0.2	Comments:		
	Span Setting	Zero Setting												
As Found	0.995	0.2												
As Left	0.995	0.2												
Comments:														
Cycle 1 Verification Data														
Cycle 1 Date: 9/10/2021 Regression Slope: 0.9890 Regression Intercept: 0.32														
	Higher Level Standard	Candidate Transfer Standard												
	Teledyne T400 SN 3121	Teledyne T700U SN 173												
			Percent Difference											
			Absolute Difference											
Zero:	0.0	0.0	NA	0.1										
Point 1:	202.1	200.0	-1.1%	-2.2										
Point 2:	161.7	159.8	-1.2%	-1.9										
Point 3:	121.6	120.2	-1.2%	-1.5										
Point 4:	90.8	90.0	-0.9%	-0.8										
Point 5:	61.2	60.0	-1.8%	-1.1										
Point 6:	38.8	38.1	-2.3%	-0.7										
Point 7:			0.0%	0.0										
Point 8:			0.0%	0.0										
Point 9:			0.0%	0.0										
Point 10:			0.0%	0.0										
Zero:	0.4	-0.3	NA	-0.6										
Cycle 2 Verification Data														
Cycle 2 Date: 9/10/2021 Regression Slope: 0.9890 Regression Intercept: 0.48														
	Higher Level Standard	Candidate Transfer Standard												
	Teledyne T400 SN 3121	Teledyne T700U SN 173												
			Percent Difference											
			Absolute Difference											
Zero:	0.1	-0.4	NA	-0.3										
Point 1:	202.1	199.6	-1.2%	-2.5										
Point 2:	162.2	160.0	-1.4%	-2.2										
Point 3:	121.7	120.3	-1.1%	-1.3										
Point 4:	91.8	90.1	-1.9%	-1.7										
Point 5:	61.3	59.8	-2.2%	-1.3										
Point 6:	38.7	38.3	-1.3%	-0.4										
Point 7:			0.0%	0.0										
Point 8:			0.0%	0.0										
Point 9:			0.0%	0.0										
Point 10:			0.0%	0.0										
Zero:	0.4	-0.5	NA	-0.8										
Cycle 3 Verification Data														
Cycle 3 Date: 9/10/2021 Regression Slope: 0.9907 Regression Intercept: 0.57														
	Higher Level Standard	Candidate Transfer Standard												
	Teledyne T400 SN 3121	Teledyne T700U SN 173												
			Percent Difference											
			Absolute Difference											
Zero:	0.5	-0.4	NA	-1.0										
Point 1:	202.2	199.8	-1.2%	-2.5										
Point 2:	162.8	160.1	-1.6%	-2.6										
Point 3:	121.8	119.8	-1.7%	-2.0										
Point 4:	91.2	89.8	-1.5%	-1.4										
Point 5:	61.3	60.0	-2.2%	-1.3										
Point 6:	31.0	30.2	-2.6%	-0.8										
Point 7:			0.0%	0.0										
Point 8:			0.0%	0.0										
Point 9:			0.0%	0.0										
Point 10:			0.0%	0.0										
Zero:	0.1	0.0	NA	-0.1										

O₃ Transfer Standard Verification Summary Sheet

Candidate Transfer Standard Information

Candidate Transfer Standard Role:	Level 3 Field
Make:	Teledyne
Model:	T7800
Serial Number:	173
Current Verification Expiration Date:	3/10/2022

Regression Slope/Intercept Summary (3 Most Recent)

	Slope	Intercept
Cycle 1 (2021-09-10)	0.9898	-0.32
Cycle 2 (2021-09-10)	0.9890	-0.48
Cycle 3 (2021-09-10)	0.9907	-0.57
Average	0.9898	-0.46
PREDICTION INTERVAL UPPER	0.9917	0.1801
PREDICTION INTERVAL LOWER	0.9834	-0.4094

Regression Slope/Intercept History

Date	Slope	Intercept
2021-09-10	0.9907	-0.57
2021-09-10	0.9890	-0.48
2021-09-10	0.9898	-0.32

Equation 10

$$\text{Standard } O_3 \text{ Conc} = \frac{1}{m} (\text{Indicated } O_3 \text{ Conc} - \bar{b})$$

Control Charts

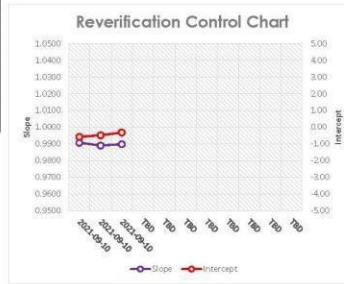

Conc. Point 1 - Scatter Plot



Conc. Point 4 - Scatter Plot

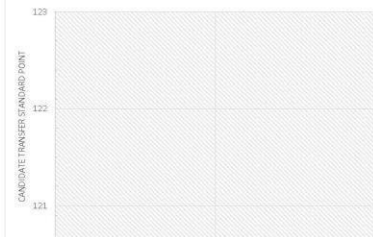

WDEQ-AQD Audit Spreadsheet Setup																																																											
<p>Date</p> <p>Visit Start Time</p> <p>Visit End Time</p> <p>Auditor</p> <p>Contractor Representative</p> <p><u>Coordinates</u></p> <p>Latitude</p> <p>Longitude</p>	<p>Site name</p> <p>Site Contractor</p> <p>Site Visit Reason</p> <p>DAS Model</p> <p>DAS S/N</p> <p>Analyzers Offline</p> <p>Analyzers Online</p> <p>Station Temperature (°C)</p>																																																										
	<table border="1" style="width: 100%; border-collapse: collapse;"> <thead> <tr> <th style="width: 40%;">Audit Equipment</th> <th style="width: 15%;">Manufacturer</th> <th style="width: 15%;">Model</th> <th style="width: 10%;">S/N</th> <th style="width: 10%;">Certification Date</th> </tr> </thead> <tbody> <tr> <td>Gas Dilution System / O₃ Level 3 Transfer Standard</td> <td></td> <td></td> <td></td> <td></td> </tr> <tr> <td>O₃ Level 2 Transfer Standard</td> <td></td> <td></td> <td></td> <td></td> </tr> <tr> <td>Zero Air System</td> <td></td> <td></td> <td></td> <td></td> </tr> </tbody> </table>	Audit Equipment	Manufacturer	Model	S/N	Certification Date	Gas Dilution System / O ₃ Level 3 Transfer Standard					O ₃ Level 2 Transfer Standard					Zero Air System																																										
Audit Equipment	Manufacturer	Model	S/N	Certification Date																																																							
Gas Dilution System / O ₃ Level 3 Transfer Standard																																																											
O ₃ Level 2 Transfer Standard																																																											
Zero Air System																																																											
		<table border="1" style="width: 100%; border-collapse: collapse;"> <tr> <td style="width: 70%;">O₃ Level 3 Transfer Standard Factors (ppm) (Slope, Intercept)</td> <td style="width: 15%;"></td> <td style="width: 15%;"></td> </tr> </table>			O ₃ Level 3 Transfer Standard Factors (ppm) (Slope, Intercept)																																																						
O ₃ Level 3 Transfer Standard Factors (ppm) (Slope, Intercept)																																																											
<p>Cylinder Company:</p> <table border="1" style="width: 100%; border-collapse: collapse;"> <thead> <tr> <th style="width: 30%;"><u>Cylinder A</u></th> <th style="width: 10%;"><u>Cert Date</u></th> <th style="width: 10%;"><u>Cert Expiration</u></th> <th style="width: 30%;"><u>Cylinder B</u></th> <th style="width: 10%;"><u>Cert Date</u></th> <th style="width: 10%;"><u>Cert Expiration</u></th> </tr> </thead> <tbody> <tr> <td colspan="3" style="text-align: center;"><i>Standard (ppm)</i></td> <td colspan="3" style="text-align: center;"><i>BTEX Mix (ppb)</i></td> </tr> <tr> <td>NO:</td> <td></td> <td></td> <td>Benzene</td> <td></td> <td></td> </tr> <tr> <td>NO_x:</td> <td></td> <td></td> <td>Ethyl Benzene</td> <td></td> <td></td> </tr> <tr> <td>SO₂:</td> <td></td> <td></td> <td>M Xylene</td> <td></td> <td></td> </tr> <tr> <td>CO</td> <td></td> <td></td> <td>O Xylene</td> <td></td> <td></td> </tr> <tr> <td>Propane:</td> <td></td> <td></td> <td>P Xylene</td> <td></td> <td></td> </tr> <tr> <td>Methane:</td> <td></td> <td></td> <td>Toluene</td> <td></td> <td></td> </tr> <tr> <td>Nitrogen:</td> <td></td> <td></td> <td>Nitrogen</td> <td></td> <td></td> </tr> </tbody> </table>			<u>Cylinder A</u>	<u>Cert Date</u>	<u>Cert Expiration</u>	<u>Cylinder B</u>	<u>Cert Date</u>	<u>Cert Expiration</u>	<i>Standard (ppm)</i>			<i>BTEX Mix (ppb)</i>			NO:			Benzene			NO _x :			Ethyl Benzene			SO ₂ :			M Xylene			CO			O Xylene			Propane:			P Xylene			Methane:			Toluene			Nitrogen:			Nitrogen					
<u>Cylinder A</u>	<u>Cert Date</u>	<u>Cert Expiration</u>	<u>Cylinder B</u>	<u>Cert Date</u>	<u>Cert Expiration</u>																																																						
<i>Standard (ppm)</i>			<i>BTEX Mix (ppb)</i>																																																								
NO:			Benzene																																																								
NO _x :			Ethyl Benzene																																																								
SO ₂ :			M Xylene																																																								
CO			O Xylene																																																								
Propane:			P Xylene																																																								
Methane:			Toluene																																																								
Nitrogen:			Nitrogen																																																								

Site Monitoring Equipment				
<u>Site Name</u>			<u>DATE</u>	
AMBIENT AIR QUALITY MONITORS ON SITE				
Parameter	Manufacturer	Model	Serial No.	Range/Span
O ₃				
NO/NO ₂ /NO _x				
NO/NO ₂ /NO _y				
P-NO _x				
CO				
SO ₂				
BTEX				
Total Hydrocarbons				



NO_x ANALYZER AUDIT

ABBR.			
CLIENT	FIELD SPECIALIST	DATE	
SITE NAME			

	AMBIENT ANALYZER	AUDIT SYSTEM
Manufacturer / Model	-	
Serial Number		
		NO AUDIT GAS
		Cylinder S/N
		Expiration Date
		Cylinder Pressure
		Delivery Pressure
		Conc. NO (ppm)
		Conc. NO _x (ppm)

FULL SCALE (ppb)	500
------------------	-----

AUDIT CRITERIA (<=)	
Percent Difference of each audit level (%)	15%
OR Absolute Difference at Level 1&2 (ppb)	1.5
Converter Efficiency	96%

NO DILUTION		GAS DILUTION SYSTEM			NO		NO ₂		NO _x	
Point	Target	Actual	Z-air Flow	Gas Flow	DAS	%Diff	DAS	Actual	DAS	%Diff
ZERO	0					N/A				N/A
SPAN	0									

Point	NO	O ₃	GAS DILUTION SYSTEM			NO			NO ₂			Linearity %	NO _x			
			Z-air Flow	O ₃ Flow	Gas Flow	Actual	DAS	%Diff	Actual	DAS	%Diff		Actual	DAS	%Diff	
ZERO	0	0						N/A			N/A	N/A				N/A
GPTZ	70	35									N/A		N/A			
GPT	70	35				N/A								N/A		
GPTZ	30	15									N/A		N/A			
GPT	30	15				N/A								N/A		
GPTZ	15	7									N/A		N/A			
GPT	15	7				N/A								N/A		
GPTZ	10	4									N/A		N/A			
GPT	10	4				N/A								N/A		

Per 40 CFR Part 50 App F 1.5.9 & 1.5.10					
[NO ₂] _{corr}	[NO ₂] _{act}	[NO] _{org}	[NO] _{mem}	[NO _x] _{org}	[NO _x] _{mem}

	NO	NO ₂	NO _x
Mean ABS % Diff			
Max ABS % Diff			

Slope			
Y-Intercept			
Correlation			

Converter Efficiency	
----------------------	--



OZONE ANALYZER AUDIT

ABBR.			
CLIENT		FIELD SPECIALIST	DATE
SITE NAME			

AUDIT STANDARD		AMBIENT ANALYZER	
Manufacturer		Manufacturer / Model	-
Model		Serial Number	
Serial Number			
		Full Scale (ppb)	500

	SLOPE	INT	AUDIT CRITERIA (<=)	
Audit Standard Correction Factors	1.0000	0.0000	Percent Difference of each audit level (%)	15%
			OR Absolute Difference at Level 1&2 (ppb)	1.5

Conc. Range (ppb)	TARGET	O3 LAMP	AUDIT STANDARD		AMBIENT ANALYZER					LEVEL
		% or mV	Display	Corrected	DAS	Diff	%Diff	%LIN	P/F	
0	0						N/A		N/A	
70-89	75									
40-69	55									
20-39	30									
0-19	15									

AMBIENT ANALYZER	
Slope	
Y-Intercept	
Correlation	

NOTES:



SULFUR DIOXIDE ANALYZER AUDIT

ABBR.			
CLIENT		FIELD SPECIALIST	DATE
SITE NAME			

	AMBIENT ANALYZER	AUDIT SYSTEM
Manufacturer / Model	-	
Serial Number		
		SO₂ AUDIT GAS
		Cylinder S/N
		Expiration Date
		Cylinder Pressure
		Delivery Pressure
		Tank Conc. (ppm)

AUDIT CRITERIA (<=)		
FULL SCALE (ppb)	500	
Percent Difference of each audit level (%)	15%	
OR Absolute Difference at Level 1&2 (ppb)	1.5	

DILUTION		GAS DILUTION SYSTEM			SO ₂				
SO ₂ Conc. Range (ppb)	TARGET	Actual	Z-air Flow	Gas Flow	DAS	%Diff	%LIN	P/F	LEVEL
0	0					N/A		N/A	
50.0-99.9	75								
20.0-49.9	35								
8.0-19.9	15								
3.0-4.9	4								
					Slope				
					Y-Intercept				
					Correlation				

NOTES:



BTEX ANALYZER AUDIT

ABBR.			
CLIENT		FIELD SPECIALIST	DATE
SITE NAME			

MANUFACTURER	
MODEL	
SERIAL NUMBER	

AUDIT GAS #1		AUDIT GAS #2	
Cylinder S/N		Cylinder S/N	
Expiration Date		Expiration Date	
Benzene (ppb)		Benzene (ppb)	
Toluene (ppb)		Toluene (ppb)	
Ethylbenzene (ppb)		Ethylbenzene (ppb)	
o-Xylene		o-Xylene	
m-Xylene		m-Xylene	
p-Xylene		p-Xylene	
Total Xylenes		Total Xylenes	

Compound	Target Value ppb	ANALYZER		
		Response	Difference	% Difference
Benzene				
Toluene				
Ethylbenzene				
Total Xylenes				

Compound	Target Value ppb	ANALYZER		
		Response	Difference	% Difference
Benzene				
Toluene				
Ethylbenzene				
Total Xylenes				

NOTES:	
--------	--

APPENDIX B: Ancillary Information

Wyoming Department of Environmental Quality – Air Quality Division



WYOMING DEPARTMENT OF
ENVIRONMENTAL
QUALITY

Appendix B – Ancillary Information For Oxides of Nitrogen/Reactive Oxides of Nitrogen Monitoring

December 2024

Revision 3

1.0 Instrument Locations

This table is based on the current WDEQ-AQD Ambient Air Monitoring Stations and Operations. For Historic locations, see Figure 1 in the QAPP.

Table 1. Monitoring Station Details

Station Name	AQS ID	Latitude	Longitude	AQD Project Manager	Contractor	Site Operator
Big Piney	56-035-0700	42.4864	-110.0989	Project Manager	Ambient Air Consultants	AQD/Contractor
Boulder	56-035-0099	42.719	-109.753	Project Manager	Ambient Air Consultants	AQD/Contractor
Casper Gaseous	56-025-0100	42.82231	-106.36501	Project Manager	Ambient Air Consultants	AQD/Contractor
Cheyenne NCore	56-021-0100	41.18235	-104.77842	Project Manager	Ambient Air Consultants	AQD/Contractor
Converse County	56-009-0100	43.10108	-105.49896	Project Manager	Ambient Air Consultants	AQD/Contractor
Daniel South	56-035-0100	42.7907	-110.0551	Project Manager	Ambient Air Consultants	AQD/Contractor
Johnson County	56-019-0004	43.87483	-106.50974	Project Manager	Ambient Air Consultants	AQD/Contractor
Juel Spring	56-035-1002	42.37350	-109.56050	Project Manager	Ambient Air Consultants	AQD/Contractor
Lysite Mobile	56-013-0005	43.27421	-107.69177	Project Manager	Ambient Air Consultants	AQD/Contractor
Moxa Arch	56-037-0300	41.75056	-109.78833	Project Manager	Ambient Air Consultants	AQD/Contractor
Pinedale Gaseous	56-035-0101	42.86982	-109.87076	Project Manager	Ambient Air Consultants	AQD/Contractor
Rock Springs Mobile	56-037-0029	41.58886	-109.23784	Project Manager	Ambient Air Consultants	AQD/Contractor
Sheridan Mobile	56-033-0007	44.80389	-106.96139	Project Manager	Ambient Air Consultants	AQD/Contractor
South Pass	56-013-0099	42.53	-108.72	Project Manager	Ambient Air Consultants	AQD/Contractor
Thunder Basin	56-005-0123	44.6522	-105.2903	Project Manager	Ambient Air Consultants	AQD/Contractor
Wamsutter	56-037-0200	41.67771	-108.02415	Project Manager	Ambient Air Consultants	AQD/Contractor

2.0 Type of Instruments

The Teledyne – Air Pollution Instruments (T-API) Models T200U, T200, 200E, and the Thermo-Fisher Scientific (Thermo) Model 42i NO_x/NO_y analyzers are self-contained, microprocessor-controlled instruments that are based on the reaction of NO (or NO_y species converted into NO) with ozone in a reaction chamber. The reaction of NO and ozone gives off one photon per molecular reaction. This photon is converted into an electrical current by a photomultiplier tube. The WDEQ-AQD only utilizes FRMs, which have been rigorously challenged by the EPA in the Research Triangle Park, North Carolina laboratory to operate within the parameters set by the EPA. The FRM designation for the WDEQ-AQD NO_x analyzers are: (Teledyne-API T200U, 200E, T200) RFNA-1194-099 and (Thermo 42i, 42i-TL) RFNA- 1289-074. Additionally, one Teledyne N500 Cavity Attenuated Phase Shift (CAPS) Spectroscopy NO_x analyzer is located at the Boulder Station and operates using a different mechanism. The FEM for this analyzer is EQNA-0514-212. The NO_y analyzer (Teledyne-API T200U/NO_y) does not have an EPA designation since it does not measure NO₂.

Table 2. Site-Specific NO_x Analyzer Details

Station Name	Instrument Make/Model	Serial Number	Calibrated Range (ppb)	Audit Frequency	AQS Method Code
Big Piney	Teledyne T200	8508	100	Semi-Annual	074
Boulder – NO _x	Teledyne 200	7626	150	Quarterly	099
Boulder – CAPS NO _x	Teledyne N500	138	150	Quarterly	256
Boulder – NO _y	Teledyne T200U	451	150	Quarterly	099
Casper Gaseous	Teledyne T200	206	200	Semi-Annual	099
Cheyenne NCore – NO _x	Teledyne T200U	398	200	Quarterly	099
Cheyenne NCore – NO _y	Teledyne T200U	391	200	Quarterly	099
Converse County	Teledyne T200	1687	200	Semi-Annual	099
Daniel South	Thermo 42i	1180430013	150	Semi-Annual	099
Johnson County	Thermo 42i-TL	1161270016	150	Semi-Annual	074
Juel Spring	Teledyne T200	8507	200	Semi-Annual	074
Lysite Mobile	TBD	TBD	TBD	Semi-Annual	TBD
Moxa Arch	Teledyne 200E	2905	200	Semi-Annual	099

Station Name	Instrument Make/Model	Serial Number	Calibrated Range (ppb)	Audit Frequency	AQS Method Code
Pinedale Gaseous	Teledyne T200	8272	150	Semi-Annual	099
Rock Springs Mobile	Thermo 42i	1180430011	500	Semi-Annual	074
Sheridan Mobile	Thermo 42i	1180430012	500	Semi-Annual	074
South Pass	Thermo 42i	0616417090	150	Semi-Annual	074
Thunder Basin	Teledyne T200	8506	150	Semi-Annual	074
Wamsutter	Thermo 42i	1161270017	500	Semi-Annual	074

3.0 AQS Coding

AQS numbers are assigned for each monitoring station and parameters. **Table 3** illustrates the AQS code used for the WDEQ-AQD program. A sample of the AQS raw data is presented below. Please note all data submitted to AQS is pipe-delimited.

```
RD|I|56|035|0700|42601|1|1|008|574|20181001|00:00|5.0|
RD|I|56|035|0700|42602|1|1|008|574|20181001|00:00|5.0|
RD|I|56|035|0700|42603|1|1|008|574|20181001|00:00|5.0|
RD|I|56|035|0099|42601|1|1|008|099|20181001|00:00|5.0|
RD|I|56|035|0099|42602|1|1|008|099|20181001|00:00|5.0|
RD|I|56|035|0099|42603|1|1|008|099|20181001|00:00|5.0|
RD|I|56|035|0099|42601|2|1|008|200|20181001|00:00|5.0|
RD|I|56|035|0099|42602|2|1|008|200|20181001|00:00|5.0|
RD|I|56|035|0099|42603|2|1|008|200|20181001|00:00|5.0|
RD|I|56|035|0099|42601|3|1|008|699|20181001|00:00|5.0|
RD|I|56|035|0099|42612|1|1|008|699|20181001|00:00|5.0|
RD|I|56|035|0099|42600|1|1|008|699|20181001|00:00|5.0|
RD|I|56|025|0100|42601|1|1|008|099|20181001|00:00|5.0|
RD|I|56|025|0100|42602|1|1|008|099|20181001|00:00|5.0|
RD|I|56|025|0100|42603|1|1|008|099|20181001|00:00|5.0|
RD|I|56|021|0100|42601|2|1|008|599|20181001|00:00|5.0|
```

The column order is defined as follows in **Table 3**:

Table 3. Example Transaction Codes for AQS

Fields	Example
Transaction Type	RD (Raw Data Type)
Action Indicator	I (Insert)
State Code	56 (Wyoming)
County Code	021 (Laramie County)
Site ID	0100 (Cheyenne NCore)
Parameter Code	42602 (NO ₂)
POC	1
Duration Code	1 (Hourly)
Reported Unit Code	008 (parts per billion)
Method Code	*See Table 2
Date	YYYYMMDD
Sample Time	HH: MM (hour- beginning)
Reported Sample Value	5.0
Null Code	AN (Machine Malfunction)
Monitor Protocol ID	(N/A)
Qualifier Code	Up to ten (10) permitted